

FuturePlus Systems Corporation



Agilent Technologies
Innovating the HP Way

Premier Solution Partner



FS2004 Users Manual

For use with Agilent Technologies Logic Analyzers

Revision 1.8

Copyright 2004 FuturePlus Systems Corporation

FuturePlus is a registered trademark of FuturePlus Systems Corporation

HOW TO REACH US	5
PRODUCT WARRANTY	6
Limitation of warranty	6
Exclusive Remedies	6
Assistance	6
INTRODUCTION	7
How to Use This Manual	7
ANALYZING THE PC CARD CARDBUS LOCAL BUS	8
Duplicating the 167xx Logic Analyzer Master Diskette	8
Accessories Supplied	8
Minimum Equipment Required	8
Signal Naming Conventions	8
Connecting the Jumpers	9
The Master L Clock - JP1	9
Current Measurements	9
JP1A and JP2A	9
Power Indicators	9
Current Protection Device	9
Swap Switches	9
SW1 and SW2	9
Test points	10
Connecting the logic analyzer to the FS2004	10
User Pins	11
How to install a PC Card Cardbus add-in card into the FS2004	11
Operation of the PC Card Cardbus add-in card	12
Series Termination Area	12
Setting up the 166x, 167x portables or the 16500 Logic Analysis System	14
Setting up the 167xx Logic Analysis System	14
Setting up the 1680/90/900 Analyzer	14

1680/90/900 Licensing	15
Loading 1680/90/900 configuration files and the General Purpose Probe feature	15
Configuration Files	16
Offline Analysis	16
The Format Menu	19
The STAT variable	20
The ADDR, ADDR_B and DATA variables	21
Using the 16517A/518A High Speed Timing Card	21
The CYCLE variable	21
Installation Quick Reference	24
Acquiring Data	25
The State Display	26
16500 Display	26
16700 Display	27
1680/90/900 Display	28
Error Messages	29
ERROR-NO DEVICE SELECTED	29
ERROR DEVSEL ASSERTED	29
SYSTEM ERROR	29
XXX input label could not be attached to.	29
XXX: input label invalid Min/Max parameters.	29
XXX: Failed to unattach from label	29
XXX: symbol could not created.	29
XXX: Could not save Label	29
XXX: Could not load Label	30
PC Mapper	32
Setting up the Analyzer from the diskette	32
Setting up the 1680/90/900 for PC Mapper	33
Acquiring Data	33
The State Display with the PC Card Cardbus PC Mapper	33
Error Messages	36
The error messages reported by the PC Card Cardbus PC Mapper are the same as those reported with the standard non mapper version of the PC Card Cardbus Inverse Assembler.	36
PC Card Cardbus PC Mapping for memory transactions	36
Interrupt Vector Table	37
PC Card Cardbus PC Mapping - I/O Transactions	40
TIMING ANALYSIS	43
Installation Quick Reference	43

Acquiring Data	43
The Waveform Display	44
Timing Analysis using the 16517A/518A High speed timing card	44
GENERAL INFORMATION	45
Characteristics	45
Preprocessor Interface Compatibility	45
Card Edge Extender Connector	45
Standards Supported	45
Power Requirements	45
Logic Analyzer Required	45
Number of Probes Used	45
Minimum Clock Period (State)	45
Signal loading	45
Operations	45
Environmental Temperature	46
Altitude	46
Humidity	46
Testing and Troubleshooting	46
Servicing	46
Signal Connections	47
Test Point pinout	47
The Preprocessor interface pinout	47
Logic Analyzer Interface module	51
FS2004 Mechanical drawings	52
Logic Analyzer Interface module	52
Probe/Extender module	53

How to reach us

For Technical Support:

FuturePlus Systems Corporation

36 Olde English Road

Bedford NH 03110

TEL: 603-471-2734

FAX: 603-471-2738

On the web <http://www.futureplus.com>

For Sales and Marketing Support:

FuturePlus Systems Corporation

TEL: 719-278-3540

FAX: 719-278-9586

On the web <http://www.futureplus.com>

FuturePlus Systems has technical sales representatives in several major countries. For an up to date listing please see

<http://www.futureplus.com/contact.html>.

Agilent Technologies is also an authorized reseller of many FuturePlus products. Contact any Agilent Technologies sales office for details.

Product Warranty

This FuturePlus Systems product has a warranty against defects in material and workmanship for a period of 1 year from the date of shipment. During the warranty period, FuturePlus Systems will, at its option, either replace or repair products proven to be defective. For warranty service or repair, this product must be returned to the factory.

For products returned to FuturePlus Systems for warranty service, the Buyer shall prepay shipping charges to FuturePlus Systems and FuturePlus Systems shall pay shipping charges to return the product to the Buyer. However, the Buyer shall pay all shipping charges, duties, and taxes for products returned to FuturePlus Systems from another country.

FuturePlus Systems warrants that its software and hardware designated by FuturePlus Systems for use with an instrument will execute its programming instructions when properly installed on that instrument. FuturePlus Systems does not warrant that the operation of the hardware or software will be uninterrupted or error-free.

Limitation of warranty

The foregoing warranty shall not apply to defects resulting from improper or inadequate maintenance by the Buyer, Buyer-supplied software or interfacing, unauthorized modification or misuse, operation outside of the environmental specifications for the product, or improper site preparation or maintenance. NO OTHER WARRANTY IS EXPRESSED OR IMPLIED. FUTUREPLUS SYSTEMS SPECIFICALLY DISCLAIMS THE IMPLIED WARRANTIES OF MERCHANTABILITY AND FITNESS FOR A PARTICULAR PURPOSE.

Exclusive Remedies

THE REMEDIES PROVIDED HEREIN ARE BUYER'S SOLE AND EXCLUSIVE REMEDIES. FUTUREPLUS SYSTEMS SHALL NOT BE LIABLE FOR ANY DIRECT, INDIRECT, SPECIAL, INCIDENTAL, OR CONSEQUENTIAL DAMAGES, WHETHER BASED ON CONTRACT, TORT, OR ANY OTHER LEGAL THEORY.

Assistance

Product maintenance agreements and other customer assistance agreements are available for FuturePlus Systems products. For assistance, contact the factory.

Introduction

The FS2004 PC Card Cardbus preprocessor and extender card performs three functions.

- The first is to act as an extender card, extending the card under test out of the PC for probing
- The second is to provide test points for the PC Card Cardbus signals to measure the power and signal fidelity.
- The third is to provide a complete interface between any PC Card Cardbus add-in slot and Logic Analyzers. The preprocessor interface connects the signals from the PC Card Cardbus to the logic analyzer inputs.

The preprocessor interface is a passive bus monitor which does not assert any signals on the PC Card Cardbus bus. The PC Card Cardbus bus signals are terminated with 90k ohm/10pf terminators so that they are matched to the logic analyzer. Since the preprocessor interface does not actively buffer the PC Card Cardbus signals no skew is introduced.

The configuration software on the diskette sets up the format specification menu of the logic analyzer for compatibility with your PC Card Cardbus target. When the state configuration file is loaded, an inverse assembler is also loaded which decodes PC Card Cardbus transactions into easy to read mnemonics.

How to Use This Manual

This manual is organized to help you quickly find the information you need.

- **Analyzing the PC Card Cardbus** chapter introduces you to the FS2004 and lists the minimum equipment required and accessories supplied for PC Card Cardbus bus analysis.
- The **State Analysis** chapter explains how to configure the FS2004 to perform state analysis on your PC Card Cardbus target
- The **Timing Analysis** chapter explains how to configure the FS2004 to perform timing analysis on your PC Card Cardbus target
- The **General Information** chapter provides information on the operating characteristics, the test point and cable header pinout and the mechanical drawing for the FS2004 module.

Analyzing the PC Card Cardbus Local Bus

Duplicating the 167xx Logic Analyzer Master Diskette

This chapter introduces you to the FS2004 and lists the minimum equipment required and accessories supplied for PC Card Cardbus Local Bus analysis. This chapter also contains information that is common to both state and timing analysis.

Before you use the FS2004 software on the 167xx logic Analyzer, make a duplicate copy of the master diskette. Then store the master diskette and use the back-up copy to configure your logic analyzer. This will help prevent the possibility of losing or destroying the original files in the event the diskette wears out, is damaged, or a file is accidentally deleted.

To make a duplicate copy, use the Duplicate Diskette operation in the disk menu of your logic analyzer. For more information, refer to the reference manual for your logic analyzer.

Accessories Supplied

The FS2004 product consists of the following accessories:

- The FS2004 hardware, which includes
 - The probe/extender module and two jumpers
 - The logic analyzer interface module and one jumper
- The inverse assembly and configuration software on a 3.5 inch diskette.
- This operating manual

Minimum Equipment Required

The minimum equipment required for analysis of a PC Card Cardbus target consists of the following equipment:

- An 165x, 1660/61/62, 1655x, 167xA, 16510A/B or 1680/90 Logic Analyzer (4 pods required)
- The FS2004 Product
- A PC Card Cardbus target

Signal Naming Conventions

This operating manual uses the same signal notation as the PCI LOCAL BUS SPECIFICATION - REVISION 2.1. That is, a # symbol at the end of a signal name indicates that the signal's active state occurs when it is at a low voltage. The absence of a # symbol indicates that the signal is active at a high voltage.

Connecting the Jumpers

There are three jumpers to be configured on the FS2004.

- JP1 on the logic analyzer interface module
- JP1A and JP2A on the Probe/Extender module

The Master L Clock - JP1

For 166x, 1655x, 167x and 1680/90 logic analyzers the jumper must be connected between pins 1 and 2 of JP1 on the logic analyzer interface module. For 1650 and 16510 logic analyzers the jumper must be connected between pins 1 and 2 of JP1 for State analysis and pins 2 and 3 for Timing analysis.

Logic Analyzer	State/Timing	JP1
166x, 1655x, 167x and 1680/90/900	State and Timing	Connect pins 1 and 2
1650 , 16510 and 16540/541	State analysis	Connect pins 1 and 2
1650 , 16510 and 16540/541	Timing analysis	Connect pins 2 and 3

Current Measurements JP1A and JP2A

The Vcc power bus may be isolated from the PC Card Cardbus socket through two jumper blocks. Both jumpers must be removed to isolate the power. A current meter can be inserted to measure a card's current consumption.

Caution: Care must be taken to insure that the current measuring device is inserted before turning on power to the host socket. Improper power sequencing may cause a damaging latchup condition.

Power Indicators

Two LED power indicators display the status of the socket's Vcc. The PWR LED indicates that power is applied to the board. When both the PWR LED and the 5V LED are lit, a Vcc of greater than approximately 3.5V is present. When only the PWR LED is lit, the Vcc is at a level of less than 3.5V.

Note: The power LEDs are designed to indicate the presence of power on the Vcc supply pins. The LEDs do not provide an accurate measurement of Vcc. Use a voltmeter to determine the actual operating voltage.

Current Protection Device

A resettable fuse protects the host from excessive current consumption from the card. Located at V1, a Raychem PolySwitch resettable fuse provides low resistance operation up to 900mA.

Swap Switches SW1 and SW2

The PC Card Cardbus Preprocessor includes two swap switches SW1 and SW2. These switches can be used to momentarily interrupt the CCD1# and CCD2# card detect signals and

simulate a card removal/insertion cycle. The switches are located on both sides of the termination area. To test the operation of the swap switches, be sure that your PC Card Software drivers are loaded. Momentarily press both swap switches simultaneously. Most software drivers will issue a removal beep followed by an insertion beep. The host socket controller may remove power when it detects that card detects have been removed.

Test points

All 68-pins of the interface are available to probe through clearly marked headers. In addition, two ground posts can be used to ground scope or high speed timing probes.

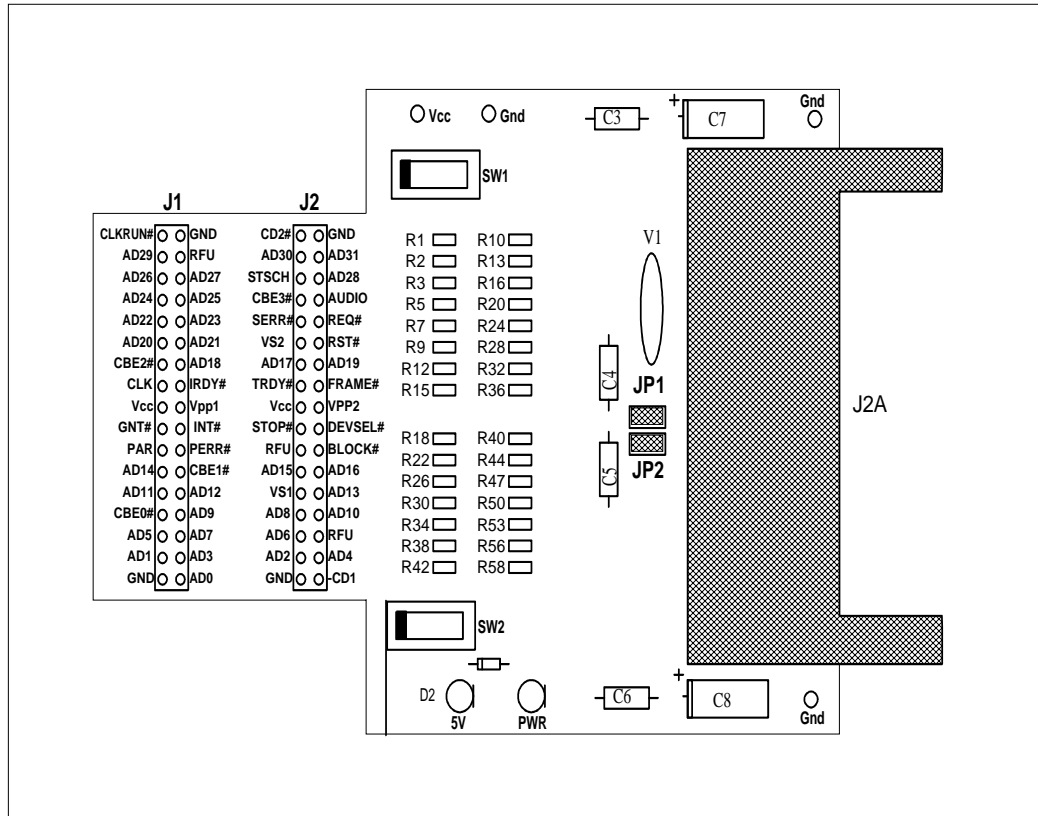

Connecting the logic analyzer to the FS2004

The following explains how to connect the logic analyzer to the FS2004 for either state or timing analysis:

1. Remove the probe tip assemblies from the logic analyzer cables.
2. Plug the logic analyzer cables into the FS2004 cable headers as shown in the appropriate table.

For 16540/541 Logic Analyzers

Logic Analyzer	FS2004	Comment
16540 Pod 1	Header 3	J clock
16541 Pod 1	Header 1	
16541 Pod 2	Header 2	
16541 Pod 3	Header 4	

All Other Logic Analyzers Except The 16540/541

Logic Analyzer	FS2004	Comment
POD 1	Header 1	
POD 2	Header 2	
POD 3	Header 3	L Clock (C3 on 1680/90)
POD 4	Header 4	

User Pins

FS2004 Header 4,2 and 1 each contains user defined pins. These pins are available to the user to connect whatever additional signals the users wishes to view along with the PC Card Cardbus signals. These pins are located on the logic analyzer interface module and clearly marked. The FS2004 configuration software will configure the user pins to appear as follows:

- User1-User4 on POD 4 channels 12 thru 15.
- User5 on POD 1 channel 16.
- User6 on POD 2 channel 16.

How to install a PC Card Cardbus add-in card into the FS2004

Using the PC Card Cardbus Preprocessor is relatively straightforward. The extender card is inserted into the desired slot in the host system. Then the PC Card Cardbus card under test is inserted into the card connector. Simply align the PC Card under test with the connector and gently push the module in until it is seated in the connector.

***Caution:** Insertion and removal of the extender and PC card should be done with care. The PC Card's fragile connectors may be broken or bent if improper force is used. Both card and extender should be inserted straight without any lateral movement or force. Proper care and use of the extender card will insure years of trouble free operation.*

Operation of the PC Card Cardbus add-in card

The nature of an extender card is that it extends the etch length of the bus. Due to the sensitivity of some PC Card Cardbus designs, extending the etch length can interfere with the PC Card Cardbus add-in card operation. Operation of the PC Card Cardbus add-in card when installed in the card edge extender connector is not guaranteed.

If poor signal fidelity is causing a problem with the add-in card operation series terminating resistors can be installed on the extender/probe card in locations R1-R62.

Series Termination Area

A series termination area located between the test points and the card connector allows access to all PC Card Cardbus signals. A series of surface mount pads allows the user to add series resistors to any signal. The SMT pads are arranged as follows:

When shipped from the factory, the resistor pads are shorted with PCB traces. In order to insert series resistor, these traces must be cut prior to soldering the resistor to the board. Figure 2.4-1 and 2.4-2 illustrate the termination areas located on both sides of the PCCextend board. Use this guide when making modifications to the board, since the silk-screen designations may be difficult to read.

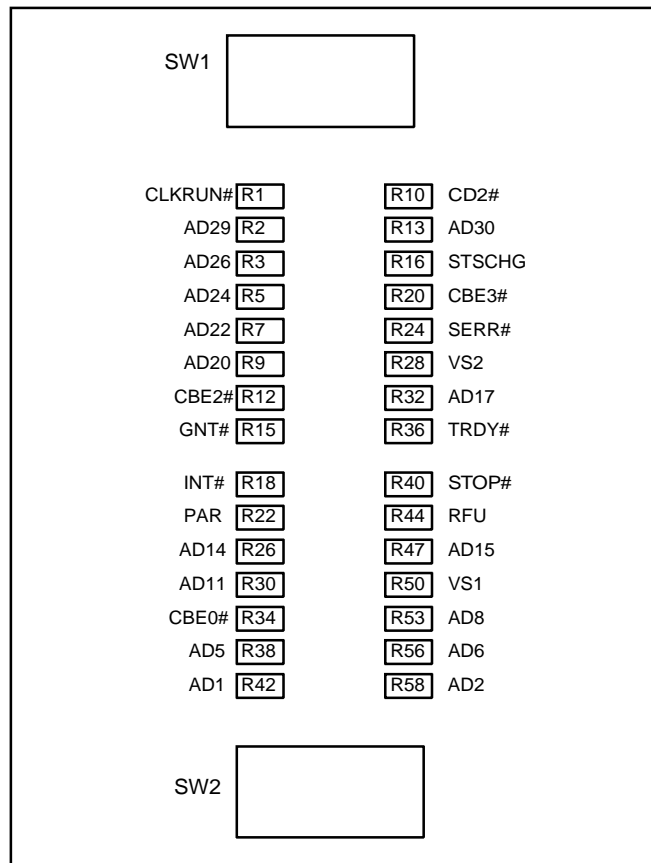

Figure 2.4-1 Termination Area - Component Side

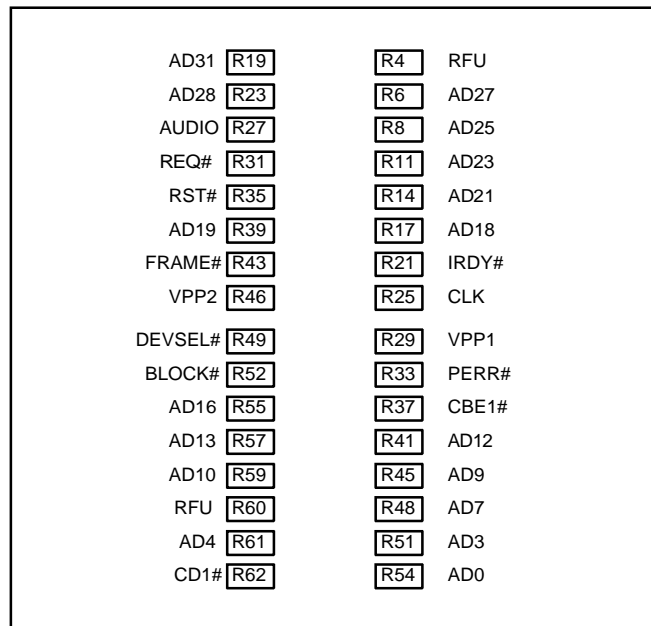

Figure 2.4-2 Termination Area - Solder Side

Setting up the 166x, 167x portables or the 16500 Logic Analysis System

The logic analyzer can be configured for PC Card Cardbus analysis by loading the PC Card Cardbus configuration file. Loading this file will load the PC Card Cardbus inverse assembler and configure your logic analyzer. To load the configuration and inverse assembler:

1. Install the FS2004 software flexible diskette in the disk drive of the logic analyzer.
2. Configure the menu to "Load" the analyzer with the appropriate configuration file (see table below).

Logic Analyzer	File name for State Analysis	File name for Timing Analysis
16555, 167x	CBUS_555	CBUS_555
166x	CBUS_660	CBUS_660
16550	CBUS_550	CBUS_550
1650 and 16510	CBUS_510S	CBUS_510T

3. Execute the load operation to load the file into the logic analyzer.

For 1655x, 167x, 16540/541 and 166x REV2.0 (system software or later) users an enhanced inverse assembler is included on the preprocessor software diskette. After loading the above file, load the file IAPCIEXE. This will configure the STATE listing menu to include INVASM OPTIONS.

Please note that 166x and 1655x, 167x users do not need to reload any files from the diskette when switching between state and timing analysis.

Setting up the 167xx Logic Analysis System

The 16600/16700 requires a special install procedure to install the PCI software. To accomplish this, insert the diskette labeled **16700/16702 PCI Analysis Probe Install disk for the FS2004** into the 16600/700 diskette drive. From the SYSTEM ADMINISTRATION TOOLS select INSTALL under SOFTWARE. From the SOFTWARE INSTALL screen select the FLEXIBLE DISK and APPLY. Once the title appears, select it and then select INSTALL. **This procedure does not need to be repeated. It only needs to be done the first time the PCI Analysis Probe is used.**

When the install is complete, load the appropriate configuration file from /logic/configs/FuturePlus/FS2004 directory.

Setting up the 1680/90/900 Analyzer

The 1680/90/900 Analyzer is a PC based application that requires a PC running the Windows OS or a 16900 frame.

Before installing the protocol decoder for the PCI protocol on a PC you **must** install the Agilent logic analyzer software. Once the Agilent logic analyzer software is installed, you can install the

FS2004 protocol decoder by placing the CD-ROM disk into the CD-ROM drive of the target computer or Analyzer and executing the .exe setup program that is contained on the disk. The .exe setup file can be executed from within the File Explorer PC Utility. You must navigate to the .exe file on the CD-ROM disk and then double click the .exe file name from within the File Explorer navigation panel.

The installation procedure does not need to be repeated. It only needs to be done the first time the Analysis Probe Adapter is used.

1680/90/900 Licensing

The PCI Inverse Assembler is a licensed product that is locked to a single hard drive. The licensing process is performed by Agilent. There are instructions on this process on the SW Entitlement certificate provided with this product.

Loading 1680/90/900 configuration files and the General Purpose Probe feature

When the software has been licensed you should be ready to load a configuration file. You can access the configuration files by clicking on the folder that was placed on the desktop. When you click on the folder it should open up to display all the configuration files to choose from. If you put your mouse cursor on the name of the file a description will appear telling you what the setup consists of, once you choose the configuration file that is appropriate for your configuration the 16900 operating system should execute. The protocol decoder automatically loads when the configuration file is loaded. If the decoder does not load, you may load it by selecting tools from the menu bar at the top of the screen and select the decoder from the list.

Once you have loaded a configuration file on the 169xx machine you can find out how to attach the logic analyzer cables to the probe by going to the workspace and selecting Properties on the General Purpose Probe tool icon that appears before the logic analyzer icon. Once you click on the Properties box a new window will appear showing which analyzer pod attaches to which probe cable.

The figure below may differ from your display; this is an example of how the display looks in general.

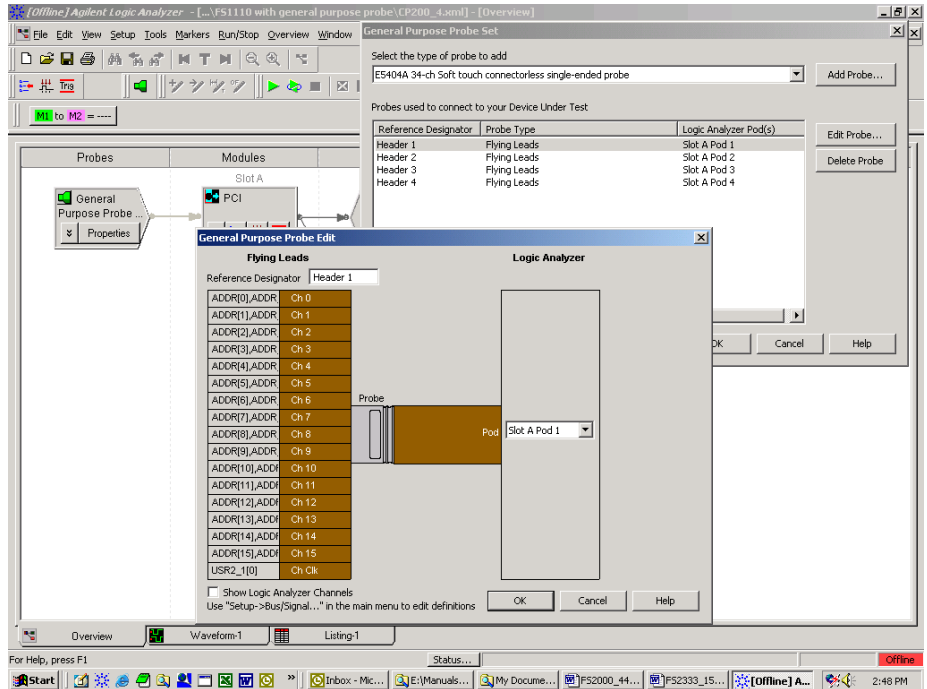

Refer to the table below for a list of analyzers and corresponding configuration files.

Configuration Files

167xx Analyzer	169xx Analyzer	State/Timing
16550		CP204_1
16555		CP204_2
16717/8/9, 16750/1/2		CP204_3
	1680/90, 16750/1/2, 1691x	CP204_4.xml

Offline Analysis

Data that is saved on a 167xx analyzer in fast binary format, or 16900 analyzer data saved as a *.ala file, can be imported into the 1680/90/900 environment for analysis. You can do offline analysis on a PC if you have the 1680/90/900 operating system installed on the PC, if you need this software please contact Agilent.

Offline analysis allows a user to be able to analyze a trace offline at a PC so it frees up the analyzer for another person to use the analyzer to capture data.

If you have already used the license that was included with your package on a 1680/90/900 analyzer and would like to have the

offline analysis feature on a PC you may buy additional licenses, please contact FuturePlus sales department.

In order to view decoded data offline, after installing the 1680/90/900 operating system on a PC, you must install the FuturePlus software. Please follow the installation instructions for "Setting up 1680/90/900 analyzer". Once the FuturePlus software has been installed and licensed follow these steps to import the data and view it.

From the desktop, double click on the Agilent logic analyzer icon. When the application comes up there will be a series of questions, answer the first question asking which startup option to use, select Continue Offline. On the analyzer type question, select cancel. When the application comes all the way up you should have a blank screen with a menu bar and tool bar at the top.

For data from a 1680/90/900 analyzer, open the .ala file using the File, Open menu selections and browse to the desired .ala file.

For data from a 16700, choose File -> Import from the menu bar, after selecting import select "yes" when it asks if the system is ready to import 16700 data.

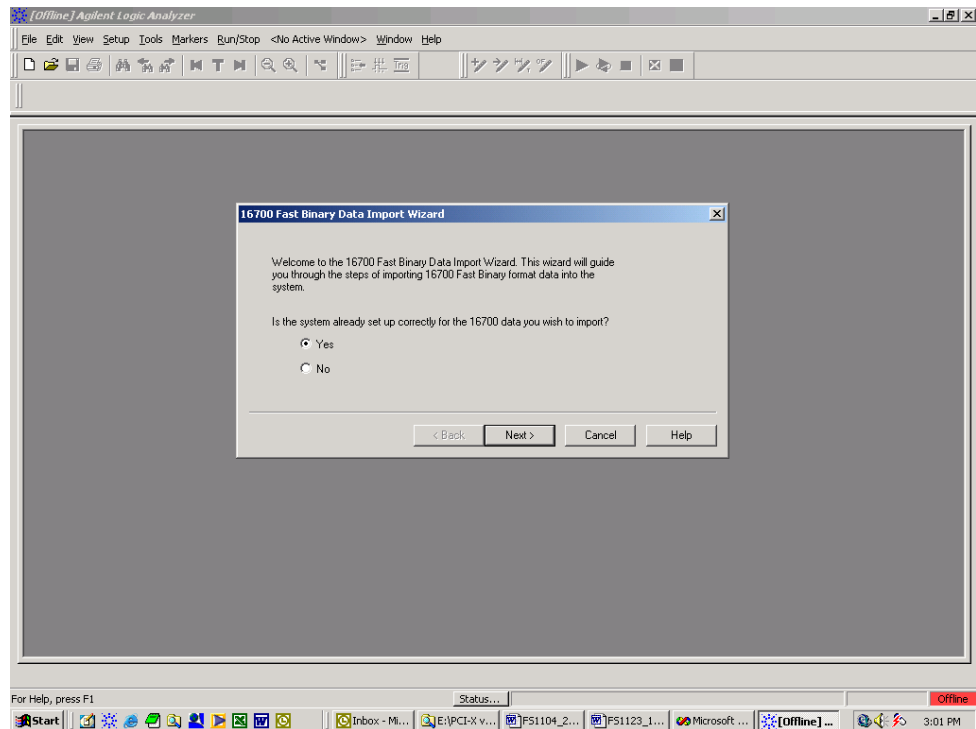

After clicking “next” you must browse for the fast binary data file you want to import. Once you have located the file and clicked start import, the data should appear in the listing.

After the data has been imported you must load the protocol decoder before you will see any decoding. To load the decoder select Tools from the menu bar, when the drop down menu appears select Inverse Assembler, then choose the name of the decoder for your particular product. The figure below is a general picture; please choose the appropriate decoder for the trace you are working with.

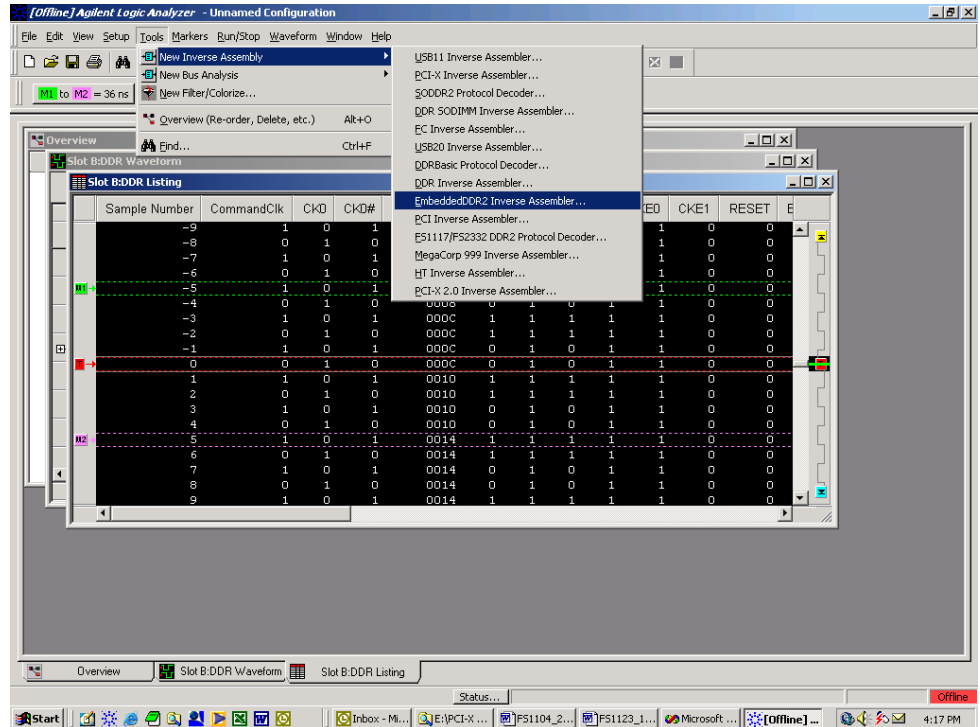

After the decoder has loaded, select Preferences if required, from the overview screen and set the preferences to their correct value in order to decode the trace properly. This is a general requirement, some decoders do not have preferences, if this is the case then no preference setting is necessary.

The Format Menu

The FS2004 diskette sets up the format menu as shown in the following table (1655x, 167x, 16510 and 166x, 1680/90). This format is the same for both Timing and State Analysis.

Label	Clk Inputs	Pod 4	Pod 3	Pod 2	Pod 1
STAT		9-0	14-0		
ADDR				15-0	15-0
ADDR_B					
USER2_1				16	16
INTD_A			14-11		
RESET			10		
C/B3_0			9-6		
DATA					15-0
DEVSEL			5		
STOP			4		
LOCK			3		
PERR			2		
SERR			1		
PAR			0		
SD/SB0		5-6			
ACK/RQ		1-0			
IRDY		7			

Label	Clk Inputs	Pod 4	Pod 3	Pod 2	Pod 1
FRAME		8			
TRDY		9			
PC Card Cardbus CLK	L				
IDSEL		2			
GNT		3			
REQ		4			
CYCLE		9-7	9-4		

The STAT variable

The STAT variable is used by the PC Card Cardbus inverse assembler to decode PC Card Cardbus bus transactions. *It should not be changed or deleted from the format menu.* The signals that make up the STAT variable are listed in the following table. The STAT variable can be useful to set up SYMBOLS since it contains all of the key PC Card Cardbus control and status signals.

STAT Variable	PC Card Cardbus Bus Signal Name
Bit 24	TRDY#
Bit 23	FRAME#
Bit 22	IRDY#
Bit 21	SDONE
Bit 20	SB0#
Bit 19	REQ#
Bit 18	GNT#
Bit 17	IDSEL
Bit 16	ACK64#
Bit 15	REQ64#
Bit 14	INTD#
Bit 13	INTC#
Bit 12	INTB#
Bit 11	INTA#

STAT Variable	PC Card Cardbus Bus Signal Name
Bit 10	RESET#
Bit 9	C/BE3#
Bit 8	C/BE2#
Bit 7	C/BE1#
Bit 6	C/BE0#
Bit 5	DEVSE#L
Bit 4	STOP#
Bit 3	LOCK#
Bit 2	PERR#
Bit 1	SERR#
Bit 0	PAR

The ADDR, ADDR_B and DATA variables

The ADDR variable is AD[31-0] bits of the PC Card Cardbus bus. The DATA variable is a dummy variable that needs to be defined for the PC Card Cardbus inverse assembler. *These variables should not be changed or deleted from the format Menu.*

Using the 16517A/518A High Speed Timing Card

The logic analyzer interface card can be removed for easy access to test points. These test points can be used to attach the flying lead set of the 16517A/518A high speed timing card. The PC Card Cardbus Preprocessor diskette has a configuration file named FS18PE that can be used as a starting point. Use this file and the stake pinout shown in the General Information chapter to connect the 16517A/518A to the FS2004 stake pins.

The CYCLE variable

The CYCLE variable is made up of the following PC Card Cardbus signals: TRDY#, FRAME#, IRDY#, C/BE(3,0), DEVSEL# and STOP#. This variable has 30 symbols defined that can be used to help make triggering, timing analysis and pattern filtering easier. The following lists the bit pattern and the corresponding symbol.

Symbol	TRDY#	FRAME#	IRDY#	C/BE(3:0)	DEVSEL#	STOP#
INTACK	1	0	1	0000	1	1
SPEC_CYC	1	0	1	0001	1	1
I/O_RD	1	0	1	0010	1	1
I/O_WR	1	0	1	0011	1	1
RESVRD	1	0	1	0100	1	1
RESVRD	1	0	1	0101	1	1
MEM_RD	1	0	1	0110	1	1
MEM_WR	1	0	1	0111	1	1
RESRVD	1	0	1	1000	1	1
RESRVD	1	0	1	1001	1	1
CON_RD	1	0	1	1010	1	1
CON_WR	1	0	1	1011	1	1
MEMRDM	1	0	1	1100	1	1
DAD_CY	1	0	1	1101	1	1
MEMRDL	1	0	1	1110	1	1
MEMWRI	1	0	1	1111	1	1
IO_XACTION	1	0	1	001X	1	1
MEM_XACTION	1	0	1	011X	1	1
CONFIG_XACTION	1	0	1	101X	1	1
ADD_CYCLE	1	0	1	XXXX	1	1
DATA_XFER	0	0	0	XXXX	0	1
WAIT_TARGET	1	X	0	XXXX	0	1
WAIT_INITIATOR	0	X	1	XXXX	0	1
DATA_FINALXFER	0	1	0	XXXX	0	1
STOP_NOXFER	X	0	1	XXXX	0	0
STOP_DATAXFER	0	X	0	XXXX	0	0
STOP_RETRY	1	1	0	XXXX	0	0
TARGET_ABORT	1	0	1	XXXX	1	0

Symbol	TRDY#	FRAME#	IRDY#	C/BE(3:0)	DEVSEL#	STOP#
IDLE	X	1	1	XXXX	X	X
WAIT_NODEVSEL	X	X	0	XXXX	1	1
WAIT_NODEVSEL/F_O	X	0	0	XXXX	1	1

State Analysis

This chapter explains how to configure the FS2004 to perform state analysis on your PC Card Cardbus target system. The configuration software sets up the format specification menu of the logic analyzer for compatibility with your PC Card Cardbus target system. The next chapter explains how to configure the FS2004 to perform timing analysis.

The FS2004 preprocessor interface does not require that a PC Card Cardbus add-in card be installed in the FS2004 card edge extender connector.

Installation Quick Reference

The following procedure describes the major steps required to perform state measurements with the FS2004 module.

1. Set the jumpers to the appropriate position on the FS2004 module. See page 9 of this manual for details.
2. After removing the probe tip assemblies, plug the logic analyzer cables into the preprocessor interface cable headers. See page 11 of this manual for details.
3. Install the FS2004 module into a slot in the target PC Card Cardbus Local bus.
4. Load the logic analyzer configuration file by loading the appropriate file. See page 14 of this manual for details.

Acquiring Data

Touch RUN and, as soon as there is activity on the bus, the logic analyzer will begin to acquire data. The analyzer will continue to acquire data and will display the data when the analyzer memory is full, the trigger specification is TRUE or when you touch STOP.

The logic analyzer will flash "Slow or Missing Clock" if it does not see the PC Card Cardbus signal CLK toggling.

To capture PCI data, click the green arrow (run) button that is located on the tool bar at the top of the screen.

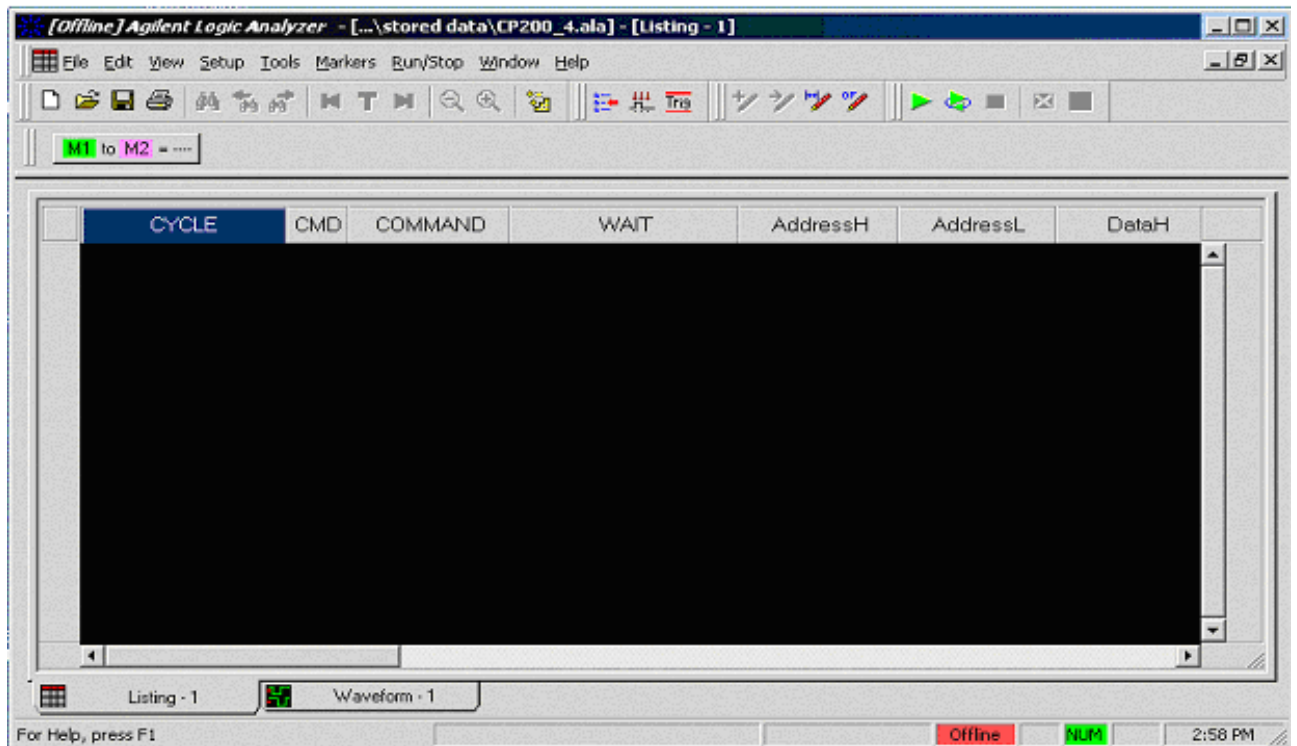

Capture Data Figure on 1680/90/900

The State Display

Captured data is as shown in the following figure. The below figure displays the state listing after disassembly. The inverse assembler is constructed so the mnemonic output closely resembles the actual commands, status conditions, messages and phases specified in the PCI Local Bus specification. Symbols have also been defined to help aid in analysis. The non-disassembled state listing displays PC Card Cardbus bus mnemonics in addition to data. All data is displayed in hex. One exception is the decode of the address for a CONFIGURATION READ or a CONFIGURATION WRITE transaction. The Function (FUNC=) and Bus (BUS=) data is displayed in decimal.

16500 Display

100/500MHz LA E	Listing 1	Print	Run
Markers Time	Trig to X 0 s	Trig to 0 0 s	X to 0 0 s
Label>	PCI BUS TRANSACTIONS	Time	C/B3_0
Base>	REV 2.2	Relative	Hex
242	D32=xxxxxxx08	296 ns	E
243	I/O READ ADR=00000073	9.072 us	2
244	D32=23xxxxxxx	1.096 us	7
245	I/O WRITE ADR=00000020	10.97 us	3
246	D32=xxxxxxx20	168 ns	E
247	INTERRUPT ACK CYCLE	54.90 ms	0
248	D32=xxxxxxx08	296 ns	E
249	I/O READ ADR=00000073	9.904 us	2
250	D32=23xxxxxxx	1.128 us	7
251	I/O WRITE ADR=00000020	10.97 us	3
252	D32=xxxxxxx20	168 ns	E

16700 Display

Listing<2>

File Window Edit Options Invasm Source Help

Goto Markers Search Comments Analysis Mixed Signal

Label ACK/RQ Hex when Present Next Prev

Advanced searching Set G1 Set G2

State Number	Time	FUTUREPLUS SYSTEMS c 1998	CYCLE	STAT	U
Decimal	Relative	PCI BUS TRANSACTIONS REV 1.1	Symbols	Hex	H
640	16.000 ns	FUNC=1 REG OFFSET=4 TYPE=00	WAIT_NODVSEL	7DF3C	0
641	76.000 ns	WAIT-NO DEVICE SELECT	STOP_DATA&XFE	7C33C	0
		COMMAND=0000			
642	4.292 us	CONFIG READ ADR=00010000	CON_RD	73FBA	0
		FUNC=0 REG OFFSET=0 TYPE=00			
643	12.000 ns	WAIT-NO DEVICE SELECT	WAIT_NODVSEL	65F30	0
644	76.000 ns	VENDOR ID=8086	STOP_DATA&XFE	64330	0
645	24.764 us	CONFIG WR ADR=00010004	CON_WR	73FFB	0
		FUNC=0 REG OFFSET=4 TYPE=00			
646	16.000 ns	WAIT-NO DEVICE SELECT	WAIT_NODVSEL	7DF3C	0
647	76.000 ns	COMMAND=0000	STOP_DATA&XFE	7C33C	0
648	28.072 ms	CONFIG READ ADR=00000000	CON_RD	73FBA	0
		FUNC=0 REG OFFSET=0 TYPE=00			
649	12.000 ns	WAIT-NO DEVICE SELECT	WAIT_NODVSEL	65F30	0
650	16.000 ns	WAIT-NO DEVICE SELECT	WAIT_NODVSEL	65F30	0

1680/90/900 Display

[Offline] Agilent Logic Analyzer - [...\stored data\CP200_4.ala] - [Listing - 1]

File Edit View Setup Tools Markers Run/Stop Window Help

M1 to M2 = 4.95 ns

LE	CMD	COMMAND	WAIT	AddressH	AddressL	DataH	DataL	Termination	Term_Code
4B	0002	I/O Read							
BB	0002		Wait-No DEVSEL						
B9	0002					xxxxxx36		Initiator	0
4B	0002	I/O Read			00000040				
BB	0002		Wait-No DEVSEL						
B8	0002							STOP Retry	3
4B	0002	I/O Read			00000040				
BB	0002		Wait-No DEVSEL						
B9	0002					xxxxxx17		Initiator	0
4F	0003	I/O Write			00000021				
B7	0003		Wait-No DEVSEL						
B5	0003					xxxxFCxx		Initiator	0
4F	0003	I/O Write			000000A1				
B7	0003		Wait-No DEVSEL						
M1	B5	0003				xxxxFDxx		Initiator	0
M2	47	0001	Spec Cyc						
	83	0001	Cmd=Halt, M...		00000001				
	83	0001		Wait-No DEVSEL					
	83	0001		Wait-No DEVSEL					
	83	0001		Wait-No DEVSEL				Mstr Abort	4
	43	0000	Int Ack		00000000				
	9B	0000		Wait-No DEVSEL					
	99	0000				50xxxx50		Initiator	0
	4F	0003	I/O Write		00000021				
	B7	0003		Wait-No DEVSEL					
	B5	0003				xxxxFDxx		Initiator	0
	4F	0003	I/O Write		00000020				
	BB	0003		Wait-No DEVSEL					
	B9	0003				xxxxxx60		Initiator	0
	4F	0003	I/O Write		00000021				
	B7	0003		Wait-No DEVSEL					

Listing - 1 Waveform - 1

For Help, press F1 Offline NUM 3:11 PM

Error Messages

The following error messages are reported by the PC Card Cardbus inverse assembler.

ERROR-NO DEVICE SELECTED

This error is displayed during a non special cycle data phase when IRDY and TRDY are asserted and DEVSEL is not asserted.

ERROR DEVSEL ASSERTED

This error is displayed during a special cycle data phase if DEVSEL is asserted.

SYSTEM ERROR

This error is displayed anytime SERR# is asserted.

1680/90/900 Errors:

XXX input label could not be attached to.

This error is displayed when the 1680/90 IA is being started and a failure occurs during the creation of an input label/column.

XXX: input label invalid Min/Max parameters.

This error is displayed during the creation of a label/column. The IA expects the label/column to fall within a min/max number of bits which has been violated.

XXX: Failed to unattach from label

This error is displayed when the 1680/90 IA is being exited and a failure occurs during the label/column destruction

XXX: output label could not be created.

This error is displayed when the 1680/90 IA is being started and a failure occurs when an output label/column is being constructed

XXX: symbol could not created.

This error is displayed when the 1680/90 IA is being started and a failure occurs when an output or input label/column symbol could not be created

XXX: Could not save Label

This error is displayed when the 1680/90 IA configuration file is being created and/or updated. The configuration data for the specified label could not be written to the file and thus will be lost.

XXX: Could not load Label

This error is displayed when the 1680/90 IA configuration file is being read. The configuration data for the specified label could not be read to the file and thus will be lost.

INVASM OPTIONS

INVASM OPTIONS is available with the following logic analyzers.

- 16505A
- 1655x, 167xA in a 16500B main frame
- 16540/541 in a 16500B main frame
- 166x series with 2.0 system software
- 167xx series

1680/90 does not implement an INVASM Options menu

INVASM OPTIONS for the 165xx can be invoked by selecting INVASM OPTIONS from the state listing display. The following selection will be displayed.

INVASM OPTIONS for the 16700 family can be invoked by selecting INVASM from the state listing display and choose filter to display the color options. Below is a display taken from the 16700 showing the filter options screen. To filter out any state just point to the state you want filtered out, and click on it. To turn back on simply click on the state again.

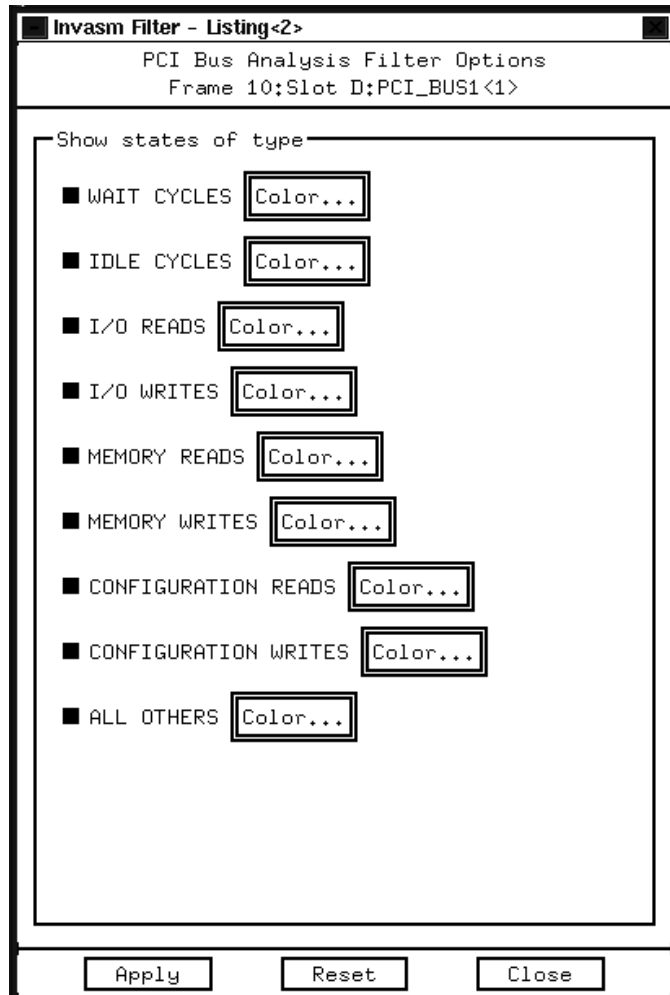

16700 Invasm Filter Options

Filtering

The acquired state listing display can be modified to filter out any combination of the above transactions or cycles by selecting the show/suppress button to the right of the transaction list.

For **16700** users, select filter under INVASM in the state listing.

For **1680/90** users, select the Filter/Colorization pull down menus in the state listing and create a filter (downstream) tool.

The 1680/90 IA allows filtering just like the 16700/702 environments. You may filter on any label, when using the filter tags label you can select symbols to make choosing transactions easier. To create a filter, choose Tools->New->Filter/Colorize. Then fill in the information on the window that opens up. You must create a new filter for each item you want filtered. To remove filters that you no longer want, go to Tools->Overview and then choose the filter you want removed and click Delete.

PC Mapper

The PC Card Cardbus Preprocessor PC Mapper software is an enhanced version of the PC Card Cardbus Preprocessor inverse assembler and is for use only with PC Card Cardbus Preprocessor from FuturePlus Systems Corporation. The enhancement includes PC Card Cardbus I/O and memory address decode to indicate common PC access.

Setting up the Analyzer from the diskette

After the configuration file is loaded the PC Card Cardbus PC Mapper software can be loaded:

1. Install the PC Card Cardbus Preprocessor software flexible diskette in the disk drive of the logic analyzer.
2. Configure the menu to "Load" the analyzer with the appropriate file (see table).

Logic Analyzer	File name
16500B mainframe with 16555, 16550, 167x, or 16540/541 logic analyzer	IAPCIMXE
16500B mainframe with 16510	IAPCIMX
16500A mainframe (all logic analyzer models)	IAPCIMX
166x series (with REV 2.2 system software)	IAPCIMXE
165x logic analyzers	IAPCIMX

3. Execute the load operation to load the file into the logic analyzer.

IFS2004E is the inverse assembler for all logic analyzers installed into the 16600/700 and is auto loaded when the configuration file is loaded.

To select PC Mapper function on the 16700, select INVASM from the state listing display then select PREFERENCES it will come up with a box and there you can choose to turn on PC Mapper or suppress PC Mapper. The picture below displays PC Mapper function enabled on the 16700.

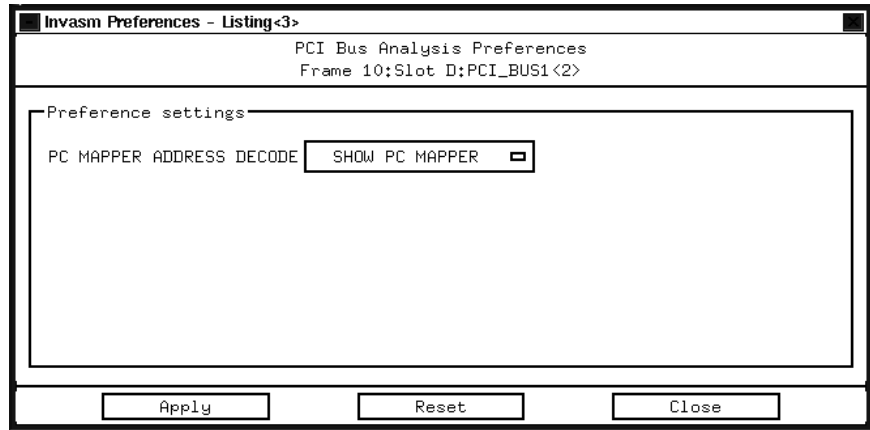

Setting up the 1680/90/900 for PC Mapper

PC Mapper is currently not available on the 1680/90/900.

Acquiring Data

Data can be acquired by touching the RUN button. As soon as there is activity on the bus, the logic analyzer will begin to acquire data. The analyzer will continue to acquire data and will display the data when the analyzer memory is full, the trigger specification is TRUE or when you touch STOP.

The logic analyzer will flash "Slow or Missing Clock" if the PC Card Cardbus Clock signal is not being detected by the logic analyzer. In this case, check the logic analyzer to PC Card Cardbus Preprocessor connection.

The State Display with the PC Card Cardbus PC Mapper

Captured data is as shown in the following figure. The first figure displays the state listing after disassembly. The PC Card Cardbus PC Mapper is constructed so the mnemonic output closely resembles the actual commands, status conditions, messages and phases specified in the PC Card Cardbus Local Bus specification. Symbols have also been defined to help aid in analysis. The non-disassembled state listing displays PC Card Cardbus bus mnemonics in addition to data. All data is displayed in hex. One exception is the decode of the address for a CONFIGURATION READ or a CONFIGURATION WRITE transaction. The Function (FUNC=) and Bus (BUS=) data is displayed in decimal.

100/500MHz LA E Listing 1 Invasm Options Print Run

Markers Time Trig to X 0 s Trig to 0 0 s X to 0 0 s

Label>	PCI BUS TRANSACTIONS	Time	C/B3_0
Base>	PC MAPPER PRE-RELEASE VERSION	Relative	Hex
39	RTC/CMOS RAM DATA PORT	2.960 us	3
40	I/O WRITE ADR=00000071 REQ64 D32=xxxx00xx	1.168 us	D
41	VIDEO MEMORY	41.55 us	7
42	MEM WRITE ADR=000B81E0 REQ64 D32=xxxxxx30	72 ns	E
43	VGA CRT CNTRLR ADDR REG	4.832 us	3
44	I/O WRITE ADR=000003D4 REQ64 D32=xxxx000E	264 ns	C
45	VGA CRT CNTRLR ADDR REG	440 ns	3
46	I/O WRITE ADR=000003D4 REQ64 D32=xxxxF10F	264 ns	C

The above display data using the PC Card Cardbus Inverse Assembly software without the PC Card Cardbus PC Mapper functionality is shown as follows.

100/500MHz LA E Listing 1 Invasm Options Print Run

Markers Time Trig to X 0 s Trig to 0 0 s X to 0 0 s

Label>	PCI BUS TRANSACTIONS	Time	C/B3_0
Base>	REV 2.2	Relative	Hex
37	I/O WRITE ADR=00000070 REQ64#	1.200 us	3
38	D32=xxxxxxx8F	1.072 us	E
39	I/O WRITE ADR=00000071 REQ64#	2.960 us	3
40	D32=xxxx00xx	1.168 us	D
41	MEM WRITE ADR=000B81E0 REQ64#	41.55 us	7
42	D32=xxxxxx30	72 ns	E
43	I/O WRITE ADR=000003D4 REQ64#	4.832 us	3
44	D32=xxxx000E	264 ns	C
45	I/O WRITE ADR=000003D4 REQ64#	440 ns	3
46	D32=xxxxF10F	264 ns	C
47	I/O WRITE ADR=00000070 REQ64#	4.064 us	3

The following listing shows the PC Mapper preference selected on the 16700.

Listing<4>

File Window Edit Options Invasm Source Help

Goto Markers Search Comments Analysis Mixed Signal

Label ACK/RQ Hex when Present Next Prev

Advanced searching Set G1 Set G2

State Number	FUTUREPLUS SYSTEMS c 2000	CYCLE	Time	USR7_1
Decimal	PCI BUS TRANSACTIONS REV 2.8	Symbols	Absolute	Hex
6P 0	SYSTEM MEMORY	MEM_RD	0 s	00
	MEM READ ADR=F3FC0000			
1	WAIT-NO DEVICE SELECT	WAIT_NODEVSE	16.000 ns	00
2	WAIT-NO DEVICE SELECT	WAIT_NODEVSE	28.000 ns	00
3	D32=12345678	DATA_FINALXF	88.000 ns	00
4	SYSTEM MEMORY	MEM_WR	111.687 ms	00
	MEM WRITE ADR=F3FC0004			
5	WAIT-NO DEVICE SELECT	WAIT_NODEVSE	111.687 ms	00
6	WAIT-NO DEVICE SELECT	WAIT_NODEVSE	111.687 ms	00
7	D32=9ABCDEF0	DATA_FINALXF	111.687 ms	00
8	SYSTEM MEMORY	MEM_RD	223.194 ms	00
	MEM READ ADR=F3FC0004			
9	WAIT-NO DEVICE SELECT	WAIT_NODEVSE	223.194 ms	00
10	WAIT-NO DEVICE SELECT	WAIT_NODEVSE	223.194 ms	00
11	D32=9ABCDEF0	DATA_FINALXF	223.195 ms	00

The following listing shows the PC Mapper preference suppressed on the 16700

Listing<4>

File Window Edit Options Invasm Source Help

Goto Markers Search Comments Analysis Mixed Signal

Label ACK/RQ Hex when Present Next Prev

Advanced searching Set G1 Set G2

State Number	FUTUREPLUS SYSTEMS c 2000	CYCLE	Time	USR7_1
Decimal	PCI BUS TRANSACTIONS REV 2.8	Symbols	Absolute	Hex
6P 0	MEM READ ADR=F3FC0000	MEM_RD	0 s	00
1	WAIT-NO DEVICE SELECT	WAIT_NODEVSE	16.000 ns	00
2	WAIT-NO DEVICE SELECT	WAIT_NODEVSE	28.000 ns	00
3	D32=12345678	DATA_FINALXF	88.000 ns	00
4	MEM WRITE ADR=F3FC0004	MEM_WR	111.687 ms	00
5	WAIT-NO DEVICE SELECT	WAIT_NODEVSE	111.687 ms	00
6	WAIT-NO DEVICE SELECT	WAIT_NODEVSE	111.687 ms	00
7	D32=9ABCDEF0	DATA_FINALXF	111.687 ms	00
8	MEM READ ADR=F3FC0004	MEM_RD	223.194 ms	00
9	WAIT-NO DEVICE SELECT	WAIT_NODEVSE	223.194 ms	00
10	WAIT-NO DEVICE SELECT	WAIT_NODEVSE	223.194 ms	00
11	D32=9ABCDEF0	DATA_FINALXF	223.195 ms	00
12	MEM WRITE ADR=F3FC0008	MEM_WR	334.826 ms	00
13	WAIT-NO DEVICE SELECT	WAIT_NODEVSE	334.826 ms	00
14	WAIT-NO DEVICE SELECT	WAIT_NODEVSE	334.826 ms	00

Error Messages

The error messages reported by the PC Card Cardbus PC Mapper are the same as those reported with the standard non mapper version of the PC Card Cardbus Inverse Assembler.

The acquired state listing display can be modified to filter out any combination of the above transactions or cycles by selecting the show/suppress button to the right of the transaction cycle list.

PC Card Cardbus PC Mapping for memory transactions

This section lists the addresses, the commands and the corresponding mapping done by the PC Card Cardbus PC Mapper software. For information on the standard PCI configuration register mapping please refer to the PCI Local Bus Specification Rev 2.1.

Address bits 23-0	PC Mapper output
greater than 0FFFFFFH	System Memory
0FFFFFF-0E0000H	System BIOS
0DFFFF-0C0000H	ROM Scan
0BFFFF-0A0000H	Video Memory
09FFFF-000400H	System Memory
0003FF-000000H	See Interrupt Vector Table

Interrupt Vector Table

Address bits 23-0	PC Mapper output
0003C4H	INT #F1-FF USER PROGRAMS
000200H	INT #80-F0 BASIC
0001E0H	INT #78-7F USER PROGRAMS
0001DCH	INT #77 IRQ15
0001D8H	INT #76 IRQ14
0001D4H	INT #75 IRQ13
0001D0H	INT #74 IRQ12
0001CCH	INT #73 IRQ11
0001C8H	INT #72 IRQ10
0001C4H	INT #71 IRQ9
0001C0H	INT #70 IRQ8
0001A0H	INT #68-6F RESERVED
00019CH	INT #67 EXP MEM MANG
000180H	INT #60-66 USER PROGRAMS
00012CH	INT #4B-5F RESERVED
000128H	INT #4A USER RTC ALARM
00011CH	INT #47-49 RESERVED
000118H	INT #46 HD DISK #1 PARAM
000110H	INT #44-45 RESERVED
00010CH	INT #43 VIDEO CHAR TABLE
000108H	INT #42 EGA BIOS
000104H	INT #41 HD DISK #0 PARAM
000100H	INT #40 FLOPPY DISK ISR
000080H	INT #20-3F RESERVED DOS
00007CH	INT #1F VIDEO CHAR TABLE
000078H	INT #1E FLOPPY PARAMS
000074H	INT #1D AVAILABLE
000070H	INT #1C AVAILABLE
00006CH	INT #1B KEYBOARD BREAK
000068H	INT #1A RTC ISR
000064H	INT #19 BOOSTRAP LOADER
000060H	INT #18 ROM BASIC
00005CH	INT #17 LPT PRINTER BIOS
000058H	INT #16 KEYBOARD BIOS
000054H	INT #15 SYS SERVICE BIOS
000050H	INT #14 SERIAL PORT BIOS
00004CH	INT #13 FLOPPY DISK BIOS
000048H	INT #12 MEM SIZE INT
000044H	INT #11 EQUIP LIST
000040H	INT #10 VIDEO BIOS
00003CH	INT #0F IRQ7 LPT1
000038H	INT #0E IRQ6 FLOPPY DISK
000034H	INT #0D IRQ5 LPT2
000030H	INT #0C IRQ4 SERIAL #1
00002CH	INT #0B IRQ3 SERIAL #2
000028H	INT #0A IRQ2 SLAVE INT
000024H	INT #09 KEYBOARD
000020H	INT #08 IRQ0 SYS TIMER
00001CH	INT #07 NUM COPROCESSOR
000018H	INT #06 INVALID OPCODE
000014H	INT #05 PRINT SCREEN
000010H	INT #04 OVERFLOW DETECT

00000CH

INT #03 BREAKPOINT TRACE

Address bits 23-0	PC Mapper output
000008H	INT #02 NMI
000004H	INT #01 SINGLE STEP
000000H	INT #00 DIVIDE BY ZERO

**PC Card Cardbus PC
Mapping - I/O
Transactions**

Address bits 23-0	PC Mapper output
0000H	MSTR DMA CH 0
0001H	MSTR DMA CH 0
0002H	MSTR DMA CH 1
0003H	MSTR DMA CH 1
0004H	MSTR DMA CH 2
0005H	MSTR DMA CH 2
0006H	MSTR DMA CH 3
0007H	MSTR DMA CH 3
0008H	MSTR DMA STAT REG
0009H	UNKNOWN IO DEVICE
000AH	MSTR DMA MASK REG
000BH	MSTR DMA MODE REG
000CH	MSTR DMA CLR BYTE PTR
000DH	MSTR DMA MSTR CLEAR
000EH	MSTR DMA CLEAR MASK
000FH	MSTR DMA WRT MASK
0018H	MSTR DMA CH EXT FUNCT REG
001AH	MSTR DMA EXT FUNCT
0020H	MSTR INT REQ REG
0021H	MSTR INT REQ REG2
0040H	INTERVAL TIMER TIMER 0
0042H	INTERVAL TIMER SPKR TIMER
0043H	INTRVAL TIMER #1 CNTRL
0044H	INTERVL TIMER #2 WATCHDOG
0047H	INTERVAL TIMER #2 CNTRL
0060H	KEYBOARD/MOUSE DATA PORT
0061H	SYSTEM CONTOL PORT B
0064H	KEYBOARD/MOUSE CMD PORT
0070H	RTC/CMOS RAM ADDR PORT
0071H	RTC/CMOS RAM DATA PORT
0074H	EXT CMOS RAM ADDR PORT
0075H	EXT CMOS RAM ADDR PORT
0076H	EXT CMOS RAM DATA PORT
0081H	CH 2 DMA PAGE REGISTER
0082H	CH 3 DMA PAGE REGISTER
0083H	CH 1 DMA PAGE REGISTER
0087H	CH 0 DMA PAGE REGISTER
0089H	CH 6 DMA PAGE REGISTER
008AH	CH 7 DMA PAGE REGISTER
008BH	CH 5 DMA PAGE REGISTER
008FH	CH 4 DMA PAGE REGISTER
0090H	ARB CNTRL POINT REG
0091H	FEEDBACK REG
0092H	SYSTEM CONTROL PORT A
0094H	SYS SETUP/CARD ENABLE REG
0096H	ADAPTOR SETUP/ENABLE REG
00A0H	SLAVE INTERRUPT CNTRLR
00A1H	SLAVE INTERRUPT CNTRLR
00C0H	SLAVE DMA CH4 MEM ADDR
00C2H	SLAVE DMA CH4 TRANS COUNT
00C4H	SLAVE DMA CH5 MEM ADDR
00C6H	SLAVE DMA CH5 TRANS COUNT

00C8H	SLAVE DMA CH6 MEM ADDR
Address bits 23-0	PC Mapper output
00CAH	SLV DMA CH6 TRANS COUNT
00CCH	SLAVE DMA CH7 MEM ADDR
00CEH	SLAVE DMA CH7 TRANS COUNT
00D0H	SLV DMA STATUS REG CH 4-7
00D4H	SLV DMA MASK REG CH 4-7
00D6H	SLAVE DMA MODE REG CH 4-7
00D8H	SLAVE DMA CLEAR BYTE PNTR
00DAH	SLAVE DMA MASTER CLEAR
00DCH	SLV DMA CLR MASK CH 4-7
00DEH	SLAVE DMA WRITE MASK REG
00E0H	IBM MODELS - ENCODE REG
00E1H	IBM MODELS - ENCODE REG
00F1H	NUMERIC COPROCESSOR RESET
00F8H	NUMERIC COPROCESSOR PORT
00F9H	NUMERIC COPROCESSOR PORT
00FAH	NUMERIC COPROCESSOR PORT
00FBH	NUMERIC COPROCESSOR PORT
00FCH	NUMERIC COPROCESSOR PORT
0100H	ADAPTER CARD POS REG 0
0101H	ADAPTER CARD POS REG 1
0102H	SYS BD/ADP CD POS REG 2
0103H	SYS BD/ADP CD POS REG 3
0104H	ADAPTER CARD POS REG 4
0105H	ADAPTER CARD POS REG 5
0106H	ADAPTER CARD POS REG 6
0107H	ADAPTER CARD POS REG 6
0278H	PARALLEL PORT 3 DATA PORT
0279H	PARALLEL PORT 3 STAT PORT
027AH	PARALLEL PORT 3 CMD PORT
02F8H	SERIAL PORT 2 XMIT/REC
02F9H	SER PORT 2 DIV LATCH/INT
02FAH	SERIAL PORT 2 INT ID REG
02FBH	SERIAL PORT 2 CNTRL REG
02FDH	SERIAL PORT 2 MODEM CNTRL
02FEH	SERIAL PORT 2 MODEM STAT
02FFH	SERIAL PORT 2 SCRTCH REG
0378H	PARALLEL PORT 2 DATA PORT
0379H	PARALLEL PORT 2 STAT PORT
037AH	PARALLEL PORT 2 CMD PORT
03B4H	VGA CRT CNTRLR ADDR REG
03B5H	VGA CRT CNTRLR DATA REG
03BAH	VGA STAT 1/FEATURE CNTRL
03BCH	PARALLEL PORT 1 DATA PORT
03BDH	PARALLEL PORT 1 STAT PORT
03BEH	PARALLEL PORT 1 CMD PORT
03C0H	VGA ATTRIBUTE CNTRLR ADDR
03C1H	VGA ATTRIBUTE CNTRLR DATA
03C2H	VGA OUTPUT/STAT REG
03C3H	VGA VIDEO SUBSYSTEM ENABLE
03C4H	VGA SEQUENCER ADDR REG
03C5H	VGA SEQUENCER DATA REG

03C6H	VIDEO DAC PEL MASK
03C7H	VIDEO DAC PAL ADDR/STAT

Address bits 23-0	PC Mapper output
03C8H	VIDEO DAC PAL ADDR/WRITE
03C9H	VIDEO DAC PALETTE DATA
03CAH	VGA FEATURE CONTROL REG
03CCH	VGA MISC OUTPUT REG
03CEH	VGA GRAPHICS CNTRLR ADDR
03CFH	VGA GRAPHICS CNTRLR ADDR
03D4H	VGA CRT CNTRLR ADDR REG
03D5H	VGA GRAPHICS CNTRLR DATA
03DAH	VGA COLOR STAT 1/FEATURE
03F0H	FLOPPY STATUS REG A
03F1H	FLOPPY STATUS REG B
03F2H	FLOPPY DIGITAL OUTPUT REG
03F4H	FLOPPY DISK CNTRLR STAT
03F5H	FLOPPY DISK CNTRLR DATA
03F7H	FLOPPY CONFIG CONTROL REG
03F8H	SERIAL PORT 1 XMIT/RCV BUF
03F9H	SER PORT 1 DIV LATCH/INT
03FAH	SERIAL PORT 1 INT ID/FIFO
03FBH	SERIAL PORT 1 LINE CNTRL
03FCH	SERIAL PORT 1 MODEM CNTRL
03FDH	SERIAL PORT 1 STAT REG
03FEH	SERIAL PORT 1 MODEM STAT
03FFH	SERIAL PORT 1 SCRATCH REG
0680H	MANUFACTURING CHECKPOINT PORT

Timing Analysis

Installation Quick Reference

Since the FS2004 interface contains only passive matching terminators it introduces negligible skew to the PC Card Cardbus Local Bus signals.

The following procedure describes the major steps required to perform timing analysis measurements with the FS2004 module.

1. Set the jumpers to the appropriate position on the FS2004 module. See page 9 of this manual for details.
2. After removing the probe tip assemblies, plug the logic analyzer cables into the logic analyzer interface module headers. See page 10 of this manual for details.
3. Install the FS2004 module into a slot in the target PC Card Cardbus Local bus.
4. Load the logic analyzer configuration file by loading the appropriate file from the preprocessor interface diskette. See page 14 of this manual for details.

Acquiring Data

Touch RUN and, as soon as there is activity on the bus, the logic analyzer will begin to acquire data. The analyzer will continue to acquire data and will display the data when the analyzer memory is full, the trigger specification is TRUE or when you touch STOP.

The logic analyzer will flash "Waiting for Trigger" if the trigger specification has not been met.

The Waveform Display

Captured data is displayed as shown in the following figure.

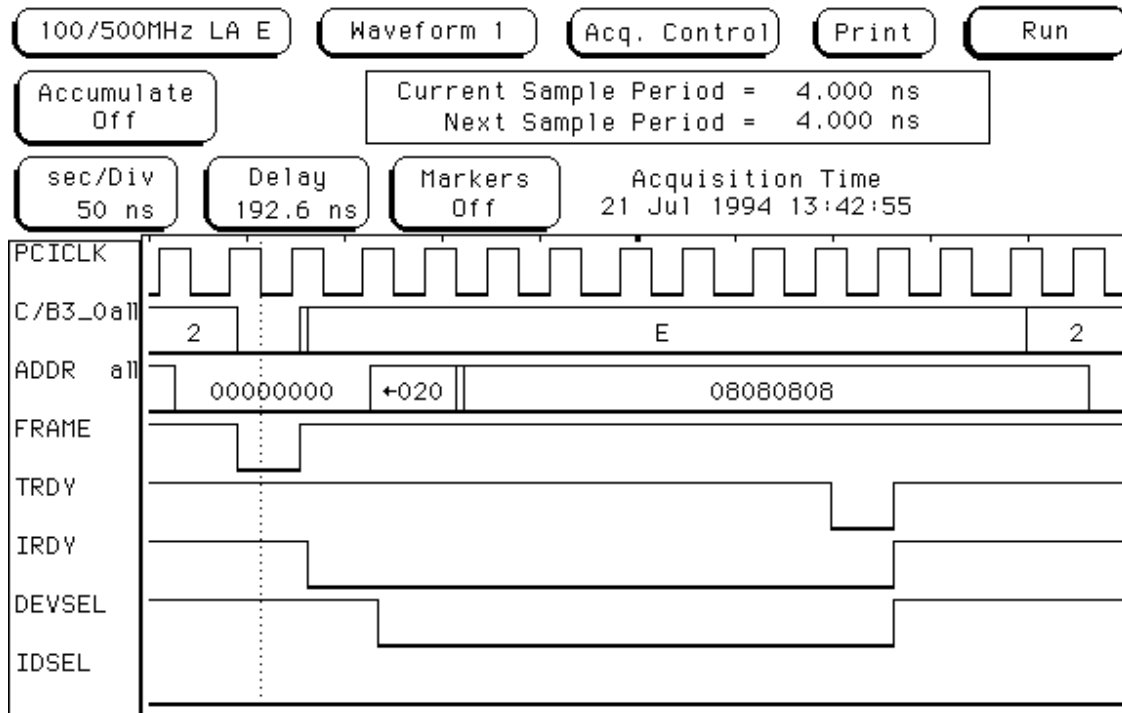

Timing Analysis using the 16517A/518A High speed timing card

Removing the logic analyzer interface module will give access to the test point area. This is a convenient way of attaching the high speed timing card. Using the 16517A/518A high speed timing card, measurements of 250ps can be made.

General Information

This chapter provides additional reference information including the characteristics and signal connections for the FS2004 module.

Characteristics

The following operating characteristics are not specifications, but are typical operating characteristics for the FS2004 module.

Preprocessor Interface Compatibility

32 bit PC Card Cardbus Local bus accepting the Type 1 form factor. All PC Card Cardbus local bus ground pins are connected to the ground plane of the Extender/Probe card and the logic analyzer interface module.

Card Edge Extender Connector

This connector is a Type 1 connector. All of the signals from the PC Card Cardbus bus are routed to the extender connector.

Standards Supported

The PCI Local Bus Specification Revision 2.1 and PC Card '95 standard.

Power Requirements

The FS2004 preprocessor draws a small amount of power from the PC Card Cardbus target for the LED. The PC Card Cardbus add-in card installed in the FS2004 can draw power from the +/- 12V, 3.3V and the 5V pins as if it were installed without the FS2004.

Logic Analyzer Required Number of Probes Used

166x, 1661, 1662, 1655x, 167x, 16510, 1650, 16540/541, 167xx, 1680/90/900. 1675x, 1695x, 1691x.

The preprocessor interface uses 4 cable headers.

Minimum Clock Period (State)

Not limited by the preprocessor interface logic. Clocking is specified by the logic analyzer.

Signal loading

The FS2004 Preprocessor logic presents one 10pf/90k ohm load on each PC Card Cardbus bus signal. The card edge extender connector adds an addition 2pf. If stake pins are installed as test points they add 1pf. If the test points are configured with an additional PC Card Cardbus connector this connector adds approximately 2pf. The etch and associated via's add approximately 1pf of additional capacitance.

Operations

All PC Card Cardbus operations supported by the hardware and the inverse assembler.

***Environmental
Temperature***

Operating: 0 to 55 degrees C (+32 to +131 degrees F)

Non operating: -40 to +75 degrees C (-40 to +167 degrees F)

Altitude

Operating: 4,600m (15,000 ft)

Non operating: 15,300m (50,000 ft)

Humidity

Up to 90% non condensing. Avoid sudden, extreme temperature changes which would cause condensation on the FS2004 module.

***Testing and
Troubleshooting***

There are no automatic performance tests or adjustments for the FS2004 module. If a failure is suspected in the FS2004 module contact the factory or your FuturePlus Systems authorized distributor.

Servicing

The repair strategy for the FS2004 is module replacement. However, if parts of the FS2004 module are damaged or lost contact the factory for a list of replacement parts.

Signal Connections

The FS2004 contains 4, forty pin headers for connection to Agilent logic analyzers and test points for scope or flying lead logic analyzer connection.

Test Point pinout

The FS2004 test points can be accessed by removing the logic analyzer interface module and attaching directly to the test points. The signal names are clearly marked on the etch.

The Preprocessor interface pinout

The logic analyzer interface module attaches to the test points on the probe/extender card. This then attaches to the logic analyzer thru 40 pin headers. The below figure displays how pins of the 40 pin cable headers are numbered.

39	37	35	33	31	29	27	25	23	21	19	17	15	13	11	9	7	5	3	1
40	38	36	34	32	30	28	26	24	22	20	18	16	14	12	10	8	6	4	2

The following tables list the FS2004 cable headers and the corresponding PC Card Cardbus signals after these signals have been terminated by the 90K ohm/10pf terminators.

Preprocessor Cable Header and Pin number	Logic Analyzer channel number	PC Card Cardbus Signal name
Header 1 pin 3	CLK/16	USER5
5	no connect	
7	15	AD15
9	14	AD14
11	13	AD13
13	12	AD12
15	11	AD11
17	10	AD10
19	9	AD09
21	8	AD08
23	7	AD07
25	6	AD06
27	5	AD05
29	4	AD04
31	3	AD03
33	2	AD02
35	1	AD01
37	0	AD00

Preprocessor Cable Header and Pin number	Logic Analyzer channel number	PC Card Cardbus Signal name
Header 2 pin 3	CLK/16	USER6
5	no connect	
7	15	AD31
9	14	AD30
11	13	AD29
13	12	AD28
15	11	AD27
17	10	AD26
19	9	AD25
21	8	AD24
23	7	AD23
25	6	AD22
27	5	AD21
29	4	AD20
31	3	AD19
33	2	AD18
35	1	AD17
37	0	AD16

Preprocessor Cable Header and Pin number	Logic Analyzer channel number	PC Card Cardbus Signal name
Header 3 pin 3	CLK/16	PCI Clock here for 166x/550 and 16510 State analysis.
5	no connect	
7	15	PCI Clock 16510 Timing analysis only.
9	14	CCLKRUN#
11	13	CCD2#
13	12	CCD1#
15	11	CINT#
17	10	RST#
19	9	C/BE3#
21	8	C/BE2#
23	7	C/BE1#
25	6	C/BE0#
27	5	DEVSEL#
29	4	STOP#
31	3	LOCK#
33	2	PERR#
35	1	SERR#
37	0	PAR

**Logic Analyzer Interface
module**

Preprocessor Cable Header and Pin number	Logic Analyzer channel number	PC Card Cardbus Signal name
Header 4 pin 3	CLK/16	
5	no connect	
7	15	USER4
9	14	USER3
11	13	USER2
13	12	USER1
15	11	VS2
17	10	VS1
19	9	TRDY#
21	8	FRAME#
23	7	IRDY#
25	6	CSTSCHG
27	5	CAUDIO
29	4	REQ#
31	3	GNT#
33	2	RFU3
35	1	RFU2
37	0	RFU1

FS2004 Mechanical drawings

Logic Analyzer Interface module

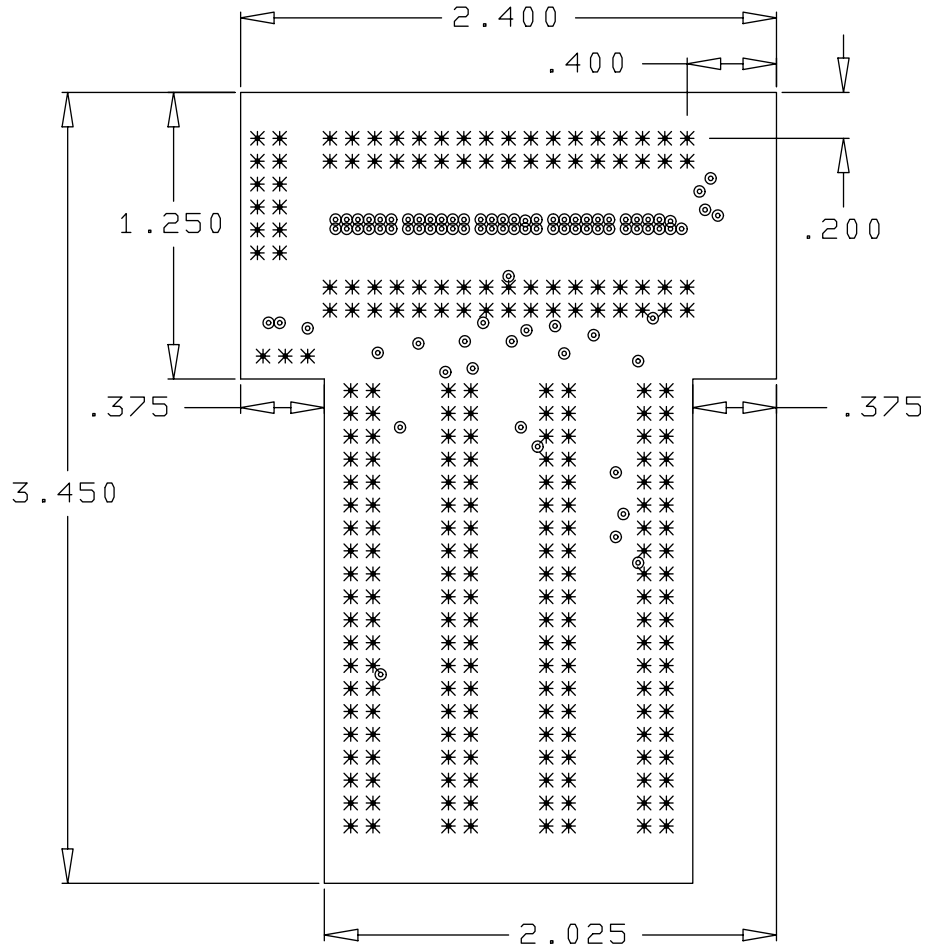

Probe/Extender module

