

**FuturePlus Systems Corporation**



**Agilent Technologies**  
Innovating the HP Way

---

Premier Solution Partner



---

# **FS2000 Users Manual**

**For use with Agilent Technologies Logic Analyzers**

**Revision 4.5**

Copyright 2004 FuturePlus Systems Corporation

FuturePlus Systems is a trademark of FuturePlus Systems Corporation

<b>HOW TO REACH US</b>	<b>5</b>
<b>PRODUCT WARRANTY</b>	<b>6</b>
<b>Limitation of warranty</b>	<b>6</b>
Exclusive Remedies	6
<b>Assistance</b>	<b>6</b>
<b>INTRODUCTION</b>	<b>7</b>
<b>How to Use This Manual</b>	<b>7</b>
<b>ANALYZING THE PCI LOCAL BUS</b>	<b>8</b>
<b>Duplicating the 167XX Logic Analyzer Master Diskette</b>	<b>8</b>
<b>Accessories Supplied</b>	<b>8</b>
<b>Minimum Equipment Required</b>	<b>8</b>
<b>Signal Naming Conventions</b>	<b>8</b>
<b>Connecting the Jumpers</b>	<b>9</b>
The Master L Clock - JP1	9
TDI/TDO-JP2	9
<b>Connecting the Agilent logic analyzer to the FS2000</b>	<b>9</b>
<b>User Pins</b>	<b>10</b>
<b>How to install a PCI add-in card into the FS2000</b>	<b>10</b>
<b>Operation of the PCI add-in card</b>	<b>10</b>
<b>Setting up the Analyzer installed in the 16500 and the portables</b>	<b>11</b>
<b>Setting up the Analyzer installed in the 16700</b>	<b>11</b>
167xx Licensing	11
<b>Setting up the 1680/90/900 Analyzer</b>	<b>13</b>
1680/90/900 licensing	13
<b>Loading 1680/90/900 configuration files and General Purpose Probe feature</b>	<b>13</b>
<b>16700 and 1680/90/900 Configuration Files</b>	<b>15</b>
<b>Offline Analysis</b>	<b>15</b>
<b>The Format Menu</b>	<b>18</b>
The STAT variable	19
The ADDR, ADDR_B and DATA variables	20
Using the 16517A/518A High Speed Timing Card	20
The CYCLE variable	20

<b>STATE ANALYSIS</b>	<b>22</b>
<b>Installation Quick Reference</b>	<b>22</b>
<b>Acquiring Data</b>	<b>22</b>
16500 Display	23
16700 Display	24
1680/90/900 Display	25
<b>Error Messages</b>	<b>26</b>
ERROR-NO DEVICE SELECTED	26
ERROR DEVSEL ASSERTED	26
SYSTEM ERROR	26
XXX input label could not be attached to.	26
XXX: input label invalid Min/Max parameters.	26
XXX: Failed to unattach from label	26
XXX: symbol could not be created.	26
XXX: Could not save Label	26
XXX: Could not load Label	27
<b>Filtering</b>	<b>28</b>
<b>Setting up the Analyzer from the diskette</b>	<b>29</b>
<b>Setting up the 16700 for PC Mapper</b>	<b>29</b>
<b>Acquiring Data</b>	<b>30</b>
<b>The State Display with the PCI PC Mapper</b>	<b>30</b>
<b>Error Messages</b>	<b>33</b>
<b>PCI PC Mapping for memory transactions</b>	<b>33</b>
<b>Interrupt Vector Table</b>	<b>34</b>
<b>PCI PC Mapping - I/O Transactions</b>	<b>36</b>
<b>TIMING ANALYSIS</b>	<b>39</b>
<b>Installation Quick Reference</b>	<b>39</b>
<b>Acquiring Data</b>	<b>39</b>
<b>The Waveform Display</b>	<b>40</b>
<b>GENERAL INFORMATION</b>	<b>41</b>
<b>Characteristics</b>	<b>41</b>
Analysis Probe Interface Compatibility	41
Card Edge Extender Connector	41
JTAG Boundary Scan	41
Standards Supported	41
Power Requirements	41
Logic Analyzer Required	41
Number of Probes Used	41

Minimum Clock Period (State)	41
Signal loading	41
Etch length	42
Operations	42
Environmental Temperature	42
Altitude	42
Humidity	42
Testing and Troubleshooting	42
Servicing	42
<b>Signal Connections</b>	<b>43</b>
Test Point pinout	43
The Analysis Probe interface pinout	43
<b>Mechanical Drawing FS2000</b>	<b>48</b>

# How to reach us

## **For Technical Support:**

FuturePlus Systems Corporation

36 Olde English Road

Bedford NH 03110

TEL: 603-471-2734

FAX: 603-471-2738

On the web <http://www.futureplus.com>

## **For Sales and Marketing Support:**

FuturePlus Systems Corporation

TEL: 719-278-3540

FAX: 719-278-9586

On the web <http://www.futureplus.com>

FuturePlus Systems has technical sales representatives in several major countries. For an up to date listing please see <http://www.futureplus.com/contact.html>.

Agilent Technologies is also an authorized reseller of many FuturePlus products. Contact any Agilent Technologies sales office for details.

# Product Warranty

This FuturePlus Systems product has a warranty against defects in material and workmanship for a period of 1 year from the date of shipment. During the warranty period, FuturePlus Systems will, at its option, either replace or repair products proven to be defective. For warranty service or repair, this product must be returned to the factory.

For products returned to FuturePlus Systems for warranty service, the Buyer shall prepay shipping charges to FuturePlus Systems and FuturePlus Systems shall pay shipping charges to return the product to the Buyer. However, the Buyer shall pay all shipping charges, duties, and taxes for products returned to FuturePlus Systems from another country.

FuturePlus Systems warrants that its software and hardware designated by FuturePlus Systems for use with an instrument will execute its programming instructions when properly installed on that instrument. FuturePlus Systems does not warrant that the operation of the hardware or software will be uninterrupted or error-free.

## **Limitation of warranty**

The foregoing warranty shall not apply to defects resulting from improper or inadequate maintenance by the Buyer, Buyer-supplied software or interfacing, unauthorized modification or misuse, operation outside of the environmental specifications for the product, or improper site preparation or maintenance. NO OTHER WARRANTY IS EXPRESSED OR IMPLIED. FUTUREPLUS SYSTEMS SPECIFICALLY DISCLAIMS THE IMPLIED WARRANTIES OF MERCHANTABILITY AND FITNESS FOR A PARTICULAR PURPOSE.

## ***Exclusive Remedies***

THE REMEDIES PROVIDED HEREIN ARE BUYER'S SOLE AND EXCLUSIVE REMEDIES. FUTUREPLUS SYSTEMS SHALL NOT BE LIABLE FOR ANY DIRECT, INDIRECT, SPECIAL, INCIDENTAL, OR CONSEQUENTIAL DAMAGES, WHETHER BASED ON CONTRACT, TORT, OR ANY OTHER LEGAL THEORY.

## **Assistance**

Product maintenance agreements and other customer assistance agreements are available for FuturePlus Systems products. For assistance, contact the factory.

# Introduction

The FS2000 PCI Analysis Probe and extender card performs three functions.

- The first is to act as an extender card, extending a module up 3 inches from the motherboard.
- The second is to provide test points very near (less than one inch) from the PCI gold finger card edge to measure the power and signal fidelity.
- The third is to provide a complete interface between any PCI add-in slot and Agilent Logic Analyzers. The Analysis Probe interface connects the signals from the PCI Local bus to the logic analyzer inputs.

The Analysis Probe interface is a passive bus monitor which does not assert any signals on the PCI bus. The PCI bus signals are terminated with 90k ohm/10pf terminators so that they are matched to the logic analyzer. Since the Analysis Probe interface does not actively buffer the PCI bus signals no skew is introduced.

The configuration software on the diskette sets up the format specification menu of the logic analyzer for compatibility with your PCI bus. When the state configuration file is loaded, an inverse assembler is also loaded which decodes PCI transactions into easy to read mnemonics.

## How to Use This Manual

This manual is organized to help you quickly find the information you need.

- **Analyzing the PCI Local Bus** chapter introduces you to the FS2000 and lists the minimum equipment required and accessories supplied for PCI bus analysis.
- The **State Analysis** chapter explains how to configure the FS2000 to perform state analysis on your PCI bus.
- The **Timing Analysis** chapter explains how to configure the FS2000 to perform timing analysis on your PCI bus.
- The **General Information** chapter provides information on the operating characteristics, the test point and cable header pinout and the mechanical drawing for the FS2000 module.

# Analyzing the PCI Local Bus

This chapter introduces you to the FS2000 and lists the minimum equipment required and accessories supplied for PCI Local Bus analysis. This chapter also contains information that is common to both state and timing analysis.

## Duplicating the 167XX Logic Analyzer Master

Before you use the FS2000 software on the 167XX series Logic Analyzer, make a duplicate copy of the master diskette. Then store the master diskette and use the back-up copy to configure your logic analyzer. This will help prevent the possibility of losing or destroying the original files in the event the diskette wears out, is damaged, or a file is accidentally deleted.

To make a duplicate copy, use the Duplicate diskette operation in the disk menu of your logic analyzer. For more information, refer to the reference manual for your logic analyzer.

## Accessories Supplied

The FS2000 product consists of the following accessories:

- The FS2000 hardware, which includes the interface circuit module.
- Two jumpers, which come installed on the circuit module.
- 3.5 inch diskette containing the inverse assembly and configuration software.
- CD-ROM containing the 1680/90 and/or Off-Line Viewer inverse assembler and configurations software.
- This operating manual

## Minimum Equipment Required

The minimum equipment required for analysis of a PCI Local Bus consists of the following equipment:

- An 165x, 166x/61/62, 1655x, 167xA, 16510A/B or 1680/90 Logic Analyzer
- The FS2000 Product
- A PCI target bus

## Signal Naming Conventions

This operating manual uses the same signal notation as the PCI LOCAL BUS SPECIFICATION - REVISION 2.0. That is, a # symbol at the end of a signal name indicates that the signal's active state occurs when it is at a low voltage. The absence of a # symbol indicates that the signal is active at a high voltage.

## Connecting the Jumpers

### The Master L Clock - JP1

There are two sets of jumpers to be configured on the FS2000. These jumpers are used to configure the master clock used for state analysis and the TDO/TDI pins.

For 166x,1655x, 167x and 1680/90 logic analyzers the jumper must be connected between pins 1 and 2 of JP1. For 1650 and 16510 logic analyzers the jumper must be connected between pins 1 and 2 of JP1 for State analysis and pins 2 and 3 for Timing analysis.

Logic Analyzer	State/Timing	JP1
166x, 1655x, 167x, and 1680/90	State and Timing	Connect pins 1 and 2
1650, 16510 and 16540/541	State analysis	Connect pins 1 and 2
1650, 16510 and 16540/541	Timing analysis	Connect pins 2 and 3

### TDI/TDO-JP2

Pin 2 of JP2 is connected to the TDI signal and pin 3 of JP2 is connected to the TDO signal. When a PCI add-in card is installed in the FS2000 card edge connector JP2 should have the jumper across pins 1 and 2. This will send the TDO and TDI signals directly to the installed add-in card. If no card is installed in the FS2000 card edge connector than JP2 should have the jumper across pins 2 and 3. This will connect TDO to TDI so that the SCAN chain is not broken.

## Connecting the Agilent logic analyzer to the FS2000

The following explains how to connect the logic analyzer to the FS2000 for either state or timing analysis when using 167xx or 165xx frames:

1. Remove the probe tip assemblies from the logic analyzer cables.
2. Plug the logic analyzer cables into the FS2000 cable headers as shown in the appropriate table.

### For 16540/541 Logic Analyzers

Logic Analyzer	FS2000	Comment
16540 Pod 1	Header 3	J clock
16541 Pod 1	Header 1	
16541 Pod 2	Header 2	
16541 Pod 3	Header 4	

### All Other Agilent Logic Analyzers Except the 16540/541

Logic Analyzer	FS2000	Comment
POD 1	Header 1	
POD 2	Header 2	
POD 3	Header 3	L Clock (C3 on 1680/90)
POD 4	Header 4	

**1680/90/9xx users** : Please refer to the "Setting up the 1680/90/900 Analyzer" for setup information

## User Pins

FS2000 Header 2 and 3 each contains one user defined pin. These pins are available to the user to connect whatever additional signals the users wishes to view along with the PCI bus. These pins are located below POD 4 on the FS2000 module and clearly marked. The FS2000 configuration software will configure user pin 1 to appear on POD 2 channel 16 and user pin 2 to appear on POD 3 channel 16.

## How to install a PCI add-in card into the FS2000

The card edge connector of the FS2000 module can accommodate one 32 bit 5V PCI add in card. Simply align the module with the connector and gently push the module in until it is seated in the connector. There is sufficient clearance for the add-in card front plate. The FS2000/PCI add-in card combination can then be installed in any slot of the PCI Local bus. For mechanical stability the FS2000 front plate should be secured to the PCI target system chassis.

When removing the PCI add-in card from the card edge extender connector grasp the FS2000 with one hand and the PCI add-in card with the other. Gently rock the PCI add-in card until it is free from the connector.

## Operation of the PCI add-in card

The nature of an extender card is that it extends the etch length of the bus. Due to the sensitivity of most PCI designs, extending the etch length can interfere with the PCI add-in card operation. Operation of the PCI add-in card when installed in the card edge extender connector is not guaranteed. Please check your system design if you experience failures due to poor signal fidelity.

## Setting up the Analyzer installed in the 16500 and the portables

The logic analyzer can be configured for PCI analysis by loading the PCI configuration file. Loading this file will load the PCI Local bus inverse assembler and configure your logic analyzer. To load the configuration and inverse assembler:

1. Install the FS2000 software flexible diskette in the disk drive of the logic analyzer.
2. Configure the menu to "Load" the analyzer with the appropriate configuration file (see table below).

Logic Analyzer	File name for State Analysis	File name for Timing Analysis
16555, 167x	F555PE	F555PE
166x	F660PE	F660PE
16550	F550PE	F550PE
1650 and 16510	F510PES	F510PET
16540/541	F540PE	F540PE

3. Execute the load operation to load the file into the logic analyzer.

*For 1655x, 167x, 16540/541 and 166x REV2.0 (system software or later) users an enhanced inverse assembler is included on the Analysis Probe software diskette. After loading the above file, load the file IAPCIEXE. This will configure the STATE listing menu to include INVASM OPTIONS.*

Please note that 166x and 1655x, 167x users do not need to reload any files from the diskette when switching between state and timing analysis.

The 16600/16700 requires a special install procedure to install the PCI Inverse Assembler. To accomplish this, insert the diskette labeled 16600/16700 ANALYSIS PROBE INSTALL DISK FOR THE FS2000 into the 16600/700 diskette drive. From the SYSTEM ADMINISTRATION TOOLS select *INSTALL* under *SOFTWARE*. From the SOFTWARE INSTALL screen select the *FLEXIBLE DISK* and *APPLY*, once the title appears select it and then select *INSTALL*.

**This procedure does not need to be repeated. It only needs to be done the first time the PCI Probe Adapter is used.**

Once the software is installed you may load the configuration file from /configs/FuturePlus/FS2000 directory. Please see table on page 13 for a list of configuration files.

The FS2000 product is a licensed product which is locked to a single Agilent 1670x frame. A demo time is provided by typing the word *demo* into the licensing area next to the product name. For use of the FS2000 product beyond the demo time please

## Setting up the Analyzer installed in the 16700

### 167xx Licensing

contact FuturePlus Systems at [www.futureplus.com](http://www.futureplus.com) or 719-278-3540. The licensing area for the 1670x mainframe is found under System Administration. Please follow the instructions on the Software Entitlement Certificate provided with this product.

The following shows the ADMIN tab under System Administration Tools.

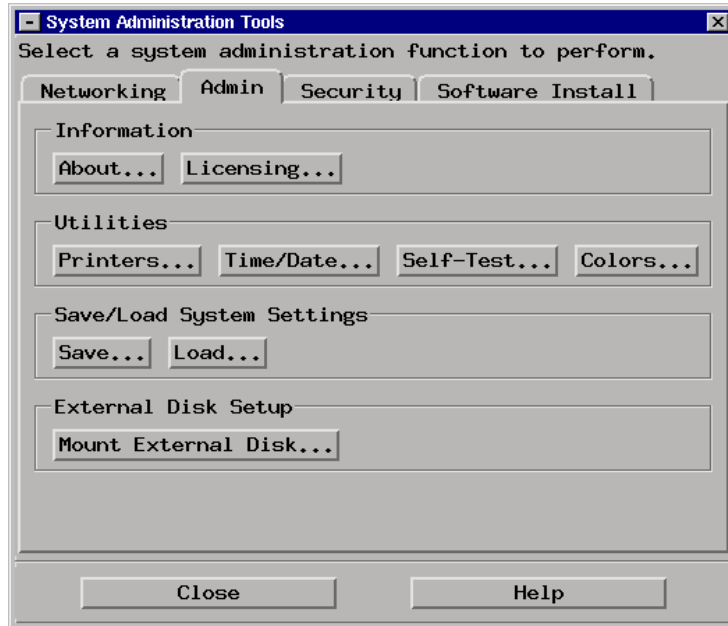

Once the FS2000 product is installed the password may be entered in the area shown below. Note: The FS2000 may not be shown specifically, this is a general picture to show where to access the licensing area.

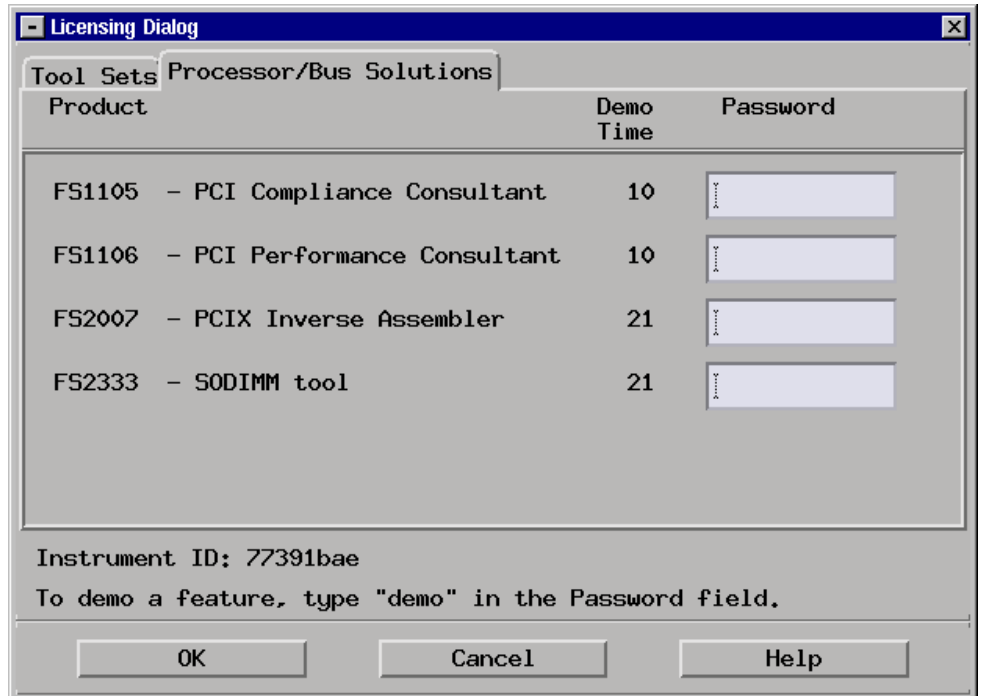

## Setting up the 1680/90/900 Analyzer

### *1680/90/900 licensing*

### Loading 1680/90/900 configuration files and General Purpose Probe feature

The 1680/90/900 Analyzer is a PC based application that requires a PC running the Windows OS or a 16900 frame.

Before installing the protocol decoder for the PCI protocol on a PC you **must** install the Agilent logic analyzer software. Once the Agilent logic analyzer software is installed, you can install the FS2000 protocol decoder by placing the CD-ROM disk into the CD-ROM drive of the target computer or Analyzer and executing the .exe setup program that is contained on the disk. The .exe setup file can be executed from within the File Explorer PC Utility. You must navigate to the .exe file on the CD-ROM disk and then double click the .exe file name from within the File Explorer navigation panel.

**The installation procedure does not need to be repeated. It only needs to be done the first time the Analysis Probe Adapter is used.**

The PCI Inverse Assembler is a licensed product that is locked to a single hard drive. The licensing process is performed by Agilent. There are instructions on this process on the SW Entitlement certificate provided with this product.

When the software has been licensed you should be ready to load a configuration file. You can access the configuration files by clicking on the folder that was placed on the desktop. When you click on the folder it should open up to display all the configuration files to choose from. If you put your mouse cursor on the name of the file a description will appear telling you what the setup consists of, once you choose the configuration file that is appropriate for your configuration the 16900 operating system should execute. The protocol decoder automatically loads when the configuration file is loaded. If the decoder does not load, you may load it by selecting tools from the menu bar at the top of the screen and select the decoder from the list.

Once you have loaded a configuration file on the 169xx machine you can find out how to attach the logic analyzer cables to the probe by going to the workspace and selecting Properties on the General Purpose Probe tool icon that appears before the logic analyzer icon. Once you click on the Properties box a new window will appear showing which analyzer pod attaches to which probe cable.

The figure below may differ from your display; this is an example of how the display looks in general.

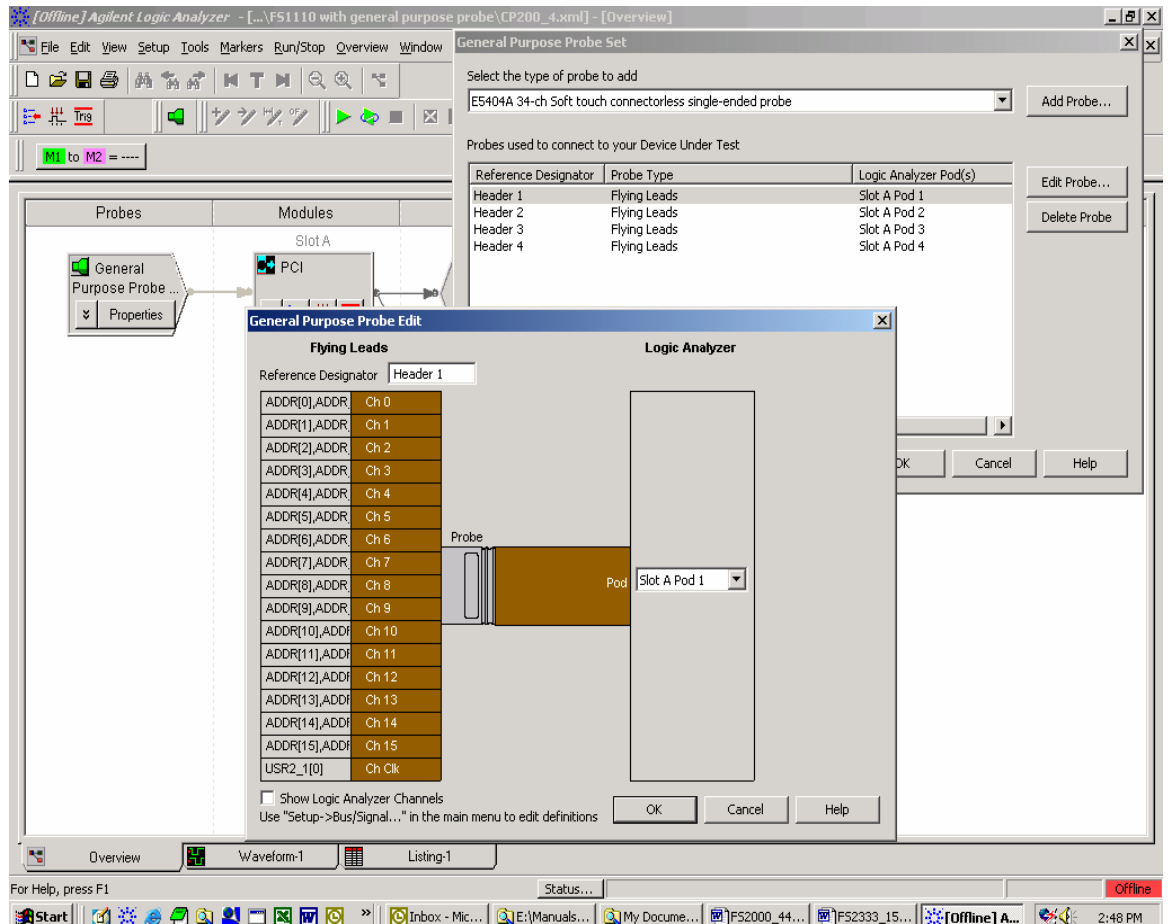

## 16700 and 1680/90/900 Configuration Files

167xx analyzer	1680/90/900 analyzer	File name for State/Timing
16715/6/7/9 16750/1/2	n/a	CP200_3
16517	n/a	F518PE
16550	n/a	F550PE
16554/5/6/7	n/a	F555PE
	16750/1/2, 1691x, 1680/90	CP200_4.xml

## Offline Analysis

Data that is saved on a 167xx analyzer in fast binary format, or 16900 analyzer data saved as a \*.ala file, can be imported into the 1680/90/900 environment for analysis. You can do offline analysis on a PC if you have the 1680/90/900 operating system installed on the PC, if you need this software please contact Agilent.

Offline analysis allows a user to be able to analyze a trace offline at a PC so it frees up the analyzer for another person to use the analyzer to capture data.

If you have already used the license that was included with your package on a 1680/90/900 analyzer and would like to have the offline analysis feature on a PC you may buy additional licenses, please contact FuturePlus sales department.

In order to view decoded data offline, after installing the 1680/90/900 operating system on a PC, you must install the FuturePlus software. Please follow the installation instructions for "Setting up 1680/90/900 analyzer". Once the FuturePlus software has been installed and licensed follow these steps to import the data and view it.

From the desktop, double click on the Agilent logic analyzer icon. When the application comes up there will be a series of questions, answer the first question asking which startup option to use, select Continue Offline. On the analyzer type question, select cancel. When the application comes all the way up you should have a blank screen with a menu bar and tool bar at the top.

For data from a 1680/90/900 analyzer, open the .ala file using the File, Open menu selections and browse to the desired .ala file.

For data from a 16700, choose File -> Import from the menu bar, after selecting import select “yes” when it asks if the system is ready to import 16700 data.

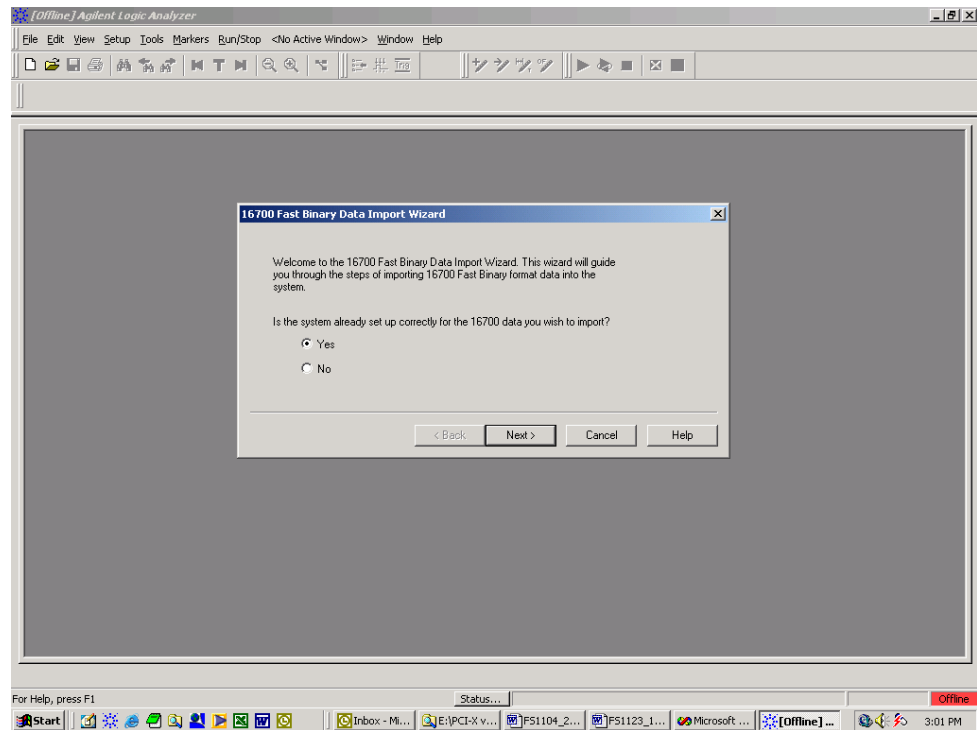

After clicking “next” you must browse for the fast binary data file you want to import. Once you have located the file and clicked start import, the data should appear in the listing.

After the data has been imported you must load the protocol decoder before you will see any decoding. To load the decoder select Tools from the menu bar, when the drop down menu appears select Inverse Assembler, then choose the name of the decoder for your particular product. The figure below is a general picture; please choose the appropriate decoder for the trace you are working with.

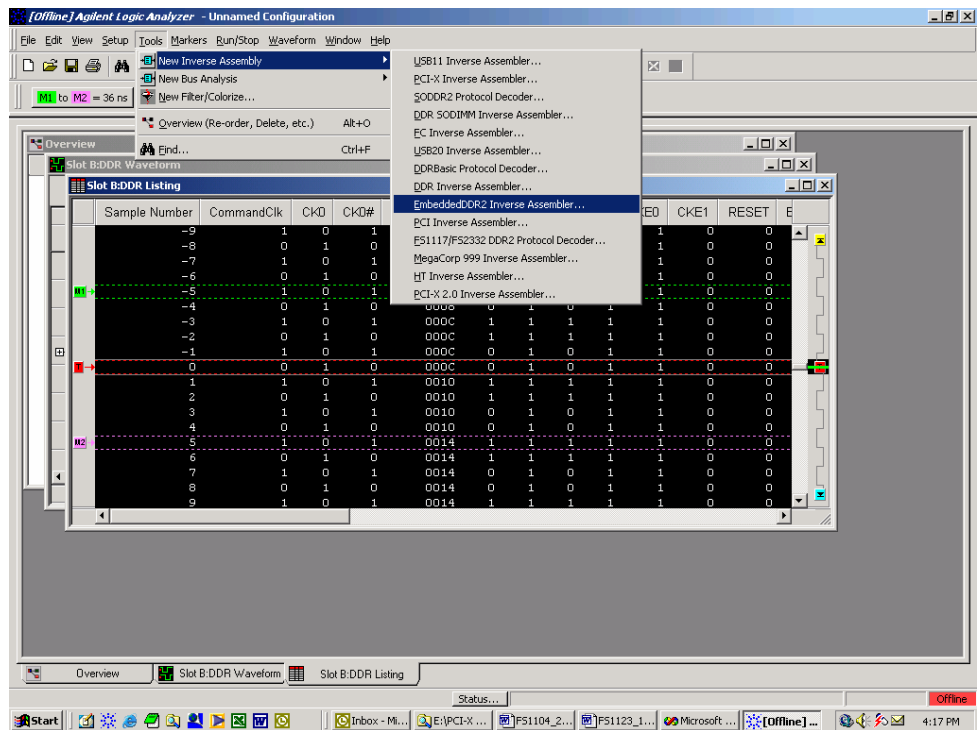

After the decoder has loaded, select Preferences if required, from the overview screen and set the preferences to their correct value in order to decode the trace properly. This is a general requirement, some decoders do not have preferences, if this is the case then no preference setting is necessary.

## The Format Menu

The FS2000 configuration files set up the format menu as shown in the following table. This format is the same for both Timing and State Analysis.

Label	Clk Inputs	Pod 4	Pod 3	Pod 2	Pod 1
STAT		9-0	14-0		
ADDR				15-0	15-0
ADDR_B					
USER2_1				16	16
INTD_A			14-11		
RESET			10		
C/B3_0			9-6		
DATA					15-0
DEVSEL			5		
STOP			4		
LOCK			3		
PERR			2		
SERR			1		
PAR			0		
SD/SB0		5-6			
ACK/RQ		1-0			
IRDY		7			
FRAME		8			
TRDY		9			
PCICLK	L				
IDSEL		2			
GNT		3			
REQ		4			
CYCLE		9-7	9-4		

## ***The STAT variable***

The STAT variable is used by the PCI inverse assembler to decode PCI bus transactions. *It should not be changed or deleted from the format menu.* The signals that make up the STAT variable are listed in the following table. The STAT variable can be useful to set up SYMBOLS since it contains all of the key PCI control and status signals.

<b>STAT Variable</b>	<b>PCI Bus Signal Name</b>
<b>Bit 24</b>	TRDY#
<b>Bit 23</b>	FRAME#
<b>Bit 22</b>	IRDY#
<b>Bit 21</b>	SDONE
<b>Bit 20</b>	SB0#
<b>Bit 19</b>	REQ#
<b>Bit 18</b>	GNT#
<b>Bit 17</b>	IDSEL
<b>Bit 16</b>	ACK64#
<b>Bit 15</b>	REQ64#
<b>Bit 14</b>	INTD#
<b>Bit 13</b>	INTC#
<b>Bit 12</b>	INTB#
<b>Bit 11</b>	INTA#
<b>Bit 10</b>	RESET#
<b>Bit 9</b>	C/BE3#
<b>Bit 8</b>	C/BE2#
<b>Bit 7</b>	C/BE1#
<b>Bit 6</b>	C/BE0#
<b>Bit 5</b>	DEVSE#L
<b>Bit 4</b>	STOP#
<b>Bit 3</b>	LOCK#
<b>Bit 2</b>	PERR#
<b>Bit 1</b>	SERR#
<b>Bit 0</b>	PAR

**The ADDR, ADDR\_B and DATA variables**

The ADDR variable is AD[31-0] bits of the PCI bus. The DATA variable is a dummy variable that needs to be defined for the PCI inverse assembler. *These variables should not be changed or deleted from the format Menu.*

**Using the 16517A/518A High Speed Timing Card**

If the FS2000 has been configured with stake pins these may be used to attach the flying lead set of the FS16517A/518A. The PCI Analysis Probe diskette has a configuration file named FS18PE that can be used as a starting point. Use this file and the stake pinout shown in the General Information chapter to connect the 16517A/518A to the FS2000 stake pins.

**The CYCLE variable**

The CYCLE variable is made up of the following PCI signals: TRDY#, FRAME#, IRDY#, C/BE(3,0), DEVSEL# and STOP#. This variable has 30 symbols defined that can be used to help make triggering, timing analysis and pattern filtering (16505A) easier. The following lists the bit pattern and the corresponding symbol.

Symbol	TRDY#	FRAME#	IRDY#	C/BE(3:0)	DEVSEL#	STOP#
INTACK	1	0	1	0000	1	1
SPEC_CYC	1	0	1	0001	1	1
I/O_RD	1	0	1	0010	1	1
I/O_WR	1	0	1	0011	1	1
RESVRD	1	0	1	0100	1	1
RESVRD	1	0	1	0101	1	1
MEM_RD	1	0	1	0110	1	1
MEM_WR	1	0	1	0111	1	1
RESRVD	1	0	1	1000	1	1
RESRVD	1	0	1	1001	1	1
CON_RD	1	0	1	1010	1	1
CON_WR	1	0	1	1011	1	1
MEMRDM	1	0	1	1100	1	1
DAD_CY	1	0	1	1101	1	1
MEMRDL	1	0	1	1110	1	1
MEMWRI	1	0	1	1111	1	1
IO_XACTION	1	0	1	001X	1	1
MEM_XACTION	1	0	1	011X	1	1

Symbol	TRDY#	FRAME#	IRDY#	C/BE(3:0)	DEVSEL#	STOP#
CONFIG_XACTION	1	0	1	101X	1	1
ADD_CYCLE	1	0	1	XXXX	1	1
DATA_XFER	0	0	0	XXXX	0	1
WAIT_TARGET	1	X	0	XXXX	0	1
WAIT_INITIATOR	0	X	1	XXXX	0	1
DATA_FINALXFER	0	1	0	XXXX	0	1
STOP_NOXFER	X	0	1	XXXX	0	0
STOP_DATAXFER	0	X	0	XXXX	0	0
STOP_RETRY	1	1	0	XXXX	0	0
TARGET_ABORT	1	0	1	XXXX	1	0
IDLE	X	1	1	XXXX	X	X
WAIT_NODEVSEL	X	1	0	XXXX	1	1
WAIT_NODEVSEL/F_O	X	0	0	XXXX	1	1

# State Analysis

This chapter explains how to configure the FS2000 to perform state analysis on the PCI Local Bus. The configuration software on the flexible diskette sets up the format specification menu of the logic analyzer for compatibility with the PCI Local Bus. The next chapter explains how to configure the FS2000 to perform timing analysis.

The FS2000 Analysis Probe interface does not require that a PCI add-in card be installed in the FS2000 card edge extender connector.

## Installation Quick Reference

The following procedure describes the major steps required to perform measurements with the FS2000 module.

1. Set the jumpers to the appropriate position on the FS2000 module. See page 9 of this manual for details.
2. After removing the probe tip assemblies, plug the logic analyzer cables into the Analysis Probe interface cable headers. See page 9 of this manual for details.
3. Install the FS2000 module into a slot in the target PCI Local bus.
4. Load the logic analyzer configuration file by loading the appropriate file. See page 11 of this manual for details.

## Acquiring Data

Touch RUN and, as soon as there is activity on the bus, the logic analyzer will begin to acquire data. The analyzer will continue to acquire data and will display the data when the analyzer memory is full, the trigger specification is TRUE or when you touch STOP.

The logic analyzer will flash "Slow or Missing Clock" if it does not see the PCI signal CLK toggling.

## The State Display

Captured data is as shown in the following figures. The below figures displays the state listing after disassembly. The inverse assembler is constructed so the mnemonic output closely resembles the actual commands, status conditions, messages and phases specified in the PCI Local Bus specification. Symbols have also been defined to help aid in analysis. The non-disassembled state listing displays PCI bus mnemonics in addition to data. All data is displayed in hex. One exception is the decode of the address for a CONFIGURATION READ or a CONFIGURATION WRITE transaction. The Function (FUNC=) and Bus (BUS=) data is displayed in decimal.

### 16500 Display

100/500MHz LA E		Listing 1		Print	Run
Markers Time		Trig to X 0 s		Trig to 0 0 s	
				X to 0 0 s	

Label> Base>	PCI BUS TRANSACTIONS REV 2.2	Time Relative	C/B3_0 Hex
242	D32=xxxxxxx08	296 ns	E
243	I/O READ ADR=00000073	9.072 us	2
244	D32=23xxxxxxx	1.096 us	7
245	I/O WRITE ADR=00000020	10.97 us	3
246	D32=xxxxxxx20	168 ns	E
247	INTERRUPT ACK CYCLE	54.90 ms	0
248	D32=xxxxxxx08	296 ns	E
249	I/O READ ADR=00000073	9.904 us	2
250	D32=23xxxxxxx	1.128 us	7
251	I/O WRITE ADR=00000020	10.97 us	3
252	D32=xxxxxxx20	168 ns	E

# 16700 Display

Listing<3>

File Edit Options Invasm Source Help

Navigate Run

Search Goto Markers Comments Analysis Mixed Signal

Label ACK/RQ Value when Present Next Prev

Advanced searching... Set G1 Set G2

State Number	FUTUREPLUS SYSTEMS c 2000	CYCLE	Time	INTD.
Decimal	PCI BUS TRANSACTIONS REV 2,8	Symbols	Relative	Hex
27	FUNC=0 REG OFFSET=4C TYPE=00 D32=xxxx00xx	DATA_FINALXF	188,000 ns	F
28	CONFIG WR ADR=0000404C	CON_WR	312,000 ns	F
30	FUNC=0 REG OFFSET=4C TYPE=00 D32=xxxxxx48	DATA_FINALXF	184,000 ns	F
31	CONFIG READ ADR=0000404C	CON_RD	220,000 ns	F
33	FUNC=0 REG OFFSET=4C TYPE=00 D32=xxxxxx48	DATA_FINALXF	156,000 ns	F
34	I/O WRITE ADR=00008020	I/O_WR	252,000 ns	F
38	D32=xxxxxx18	DATA_FINALXF	656,000 ns	F
39	I/O WRITE ADR=00008021	I/O_WR	220,000 ns	F
43	D32=xxxx6Axx	DATA_FINALXF	780,000 ns	F
44	I/O WRITE ADR=00008022	I/O_WR	188,000 ns	F
48	D32=xx29xxxx	DATA_FINALXF	812,000 ns	F
49	I/O WRITE ADR=00002400	I/O_WR	312,000 ns	F
53	D32=xxxxxx37	DATA_FINALXF	688,000 ns	F
54	I/O WRITE ADR=00006008	I/O_WR	6,262 ms	F
58	D32=xxxxxx0C	DATA_FINALXF	656,000 ns	F

# 1680/90/900 Display

[Offline] Agilent Logic Analyzer - [...\stored data\CP200\_4.ala] - [Listing - 1]

File Edit View Setup Tools Markers Run/Stop Window Help

M1 to M2 = 4.95 ns

LE	CMD	COMMAND	WAIT	AddressH	AddressL	DataH	DataL	Termination	Term_Code
4B	0002	I/O Read							
BB	0002		Wait-No DEVSEL						
B9	0002						xxxxxx36	Initiator	0
4B	0002	I/O Read			00000040				
BB	0002		Wait-No DEVSEL						
B8	0002							STOP Retry	3
4B	0002	I/O Read			00000040				
BB	0002		Wait-No DEVSEL						
B9	0002						xxxxxx17	Initiator	0
4F	0003	I/O Write			00000021				
B7	0003		Wait-No DEVSEL						
B5	0003						xxxxFCxx	Initiator	0
4F	0003	I/O Write			000000A1				
B7	0003		Wait-No DEVSEL						
M1	B5	0003					xxxxFDxx	Initiator	0
M2	47	0001	Spec Cyc						
83	0001	Cmd=Halt, M...			00000001				
83	0001		Wait-No DEVSEL						
83	0001		Wait-No DEVSEL						
83	0001		Wait-No DEVSEL					Mstr Abort	4
43	0000	Int Ack			00000000				
9B	0000		Wait-No DEVSEL						
99	0000						50xxxx50	Initiator	0
4F	0003	I/O Write			00000021				
B7	0003		Wait-No DEVSEL						
B5	0003						xxxxFDxx	Initiator	0
4F	0003	I/O Write			00000020				
BB	0003		Wait-No DEVSEL						
B9	0003						xxxxxx60	Initiator	0
4F	0003	I/O Write			00000021				
B7	0003		Wait-No DEVSEL						

Listing - 1    Waveform - 1

## Error Messages

The following error messages are reported by the PCI inverse assembler

### ERROR-NO DEVICE SELECTED

This error is displayed during a non special cycle data phase when IRDY and TRDY are asserted and DEVSEL is not asserted.

### ERROR DEVSEL ASSERTED

This error is displayed during a special cycle data phase if DEVSEL is asserted.

### SYSTEM ERROR

This error is displayed anytime SERR# is asserted.

### 1680/90/900 Errors:

XXX input label could not be attached to.

This error is displayed when the 1680/90/900 IA is being started and a failure occurs during the creation of an input label/column.

XXX: input label invalid Min/Max parameters.

This error is displayed during the creation of a label/column. The IA expects the label/column to fall within a min/max number of bits which has been violated.

XXX: Failed to unattach from label

This error is displayed when the 1680/90 IA is being exited and a failure occurs during the label/column destruction

XXX: output label could not be created.

This error is displayed when the 1680/90 IA is being started and a failure occurs when an output label/column is being constructed

XXX: symbol could not be created.

This error is displayed when the 1680/90 IA is being started and a failure occurs when an output or input label/column symbol could not be created

XXX: Could not save Label

This error is displayed when the 1680/90/900 IA configuration file is being created and/or updated. The configuration data for the

specified label could not be written to the file and thus will be lost.

XXX: Could not load Label

This error is displayed when the 1680/90/900 IA configuration file is being read. The configuration data for the specified label could not be read to the file and thus will be lost.

## INVASM OPTIONS

**INVASM OPTIONS** is available with the following logic analyzers.

- 16505A
- 1655x, 167xA in a 16500B main frame
- 16540/541 in a 16500B main frame
- 166x series with 2.0 system software
- 16700 logic analysis system

**1680/90/900** does not implement an INVASM Options menu

INVASM OPTIONS can be invoked on the 16500 by selecting INVASM OPTIONS from the state listing display. The following selection will be displayed.

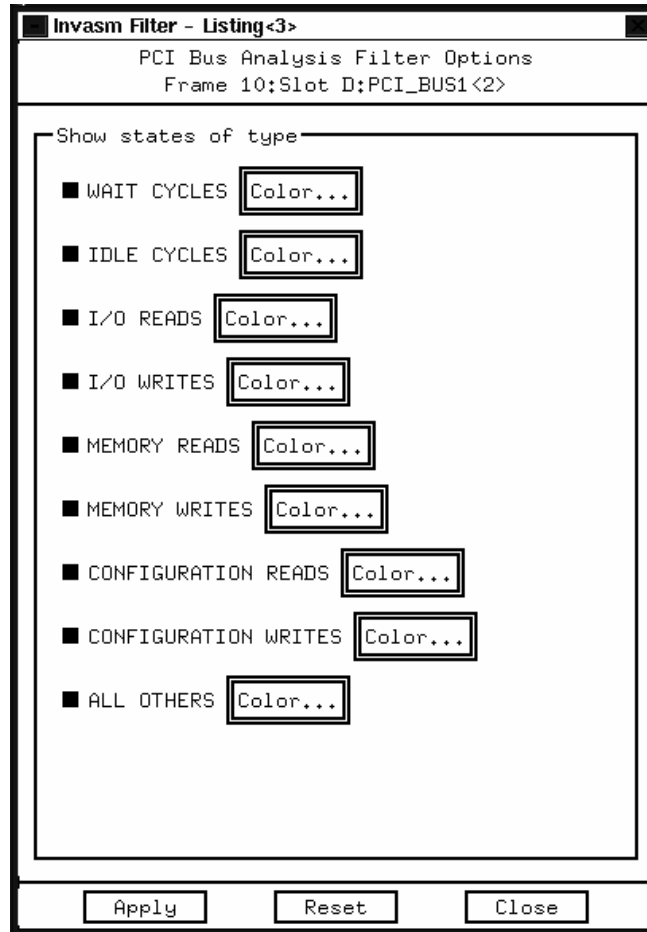

**16700 Display showing invasm options**

## Filtering

The acquired state listing display can be modified to filter out any combination of the above transactions or cycles by selecting the show/suppress button to the right of the transaction list.

For **16700** users, select filter under INVASM in the state listing.

For **1680/90/900** users, select the Filter/Colorization pull down menus in the state listing and create a filter (downstream) tool.

The 1680/90/900 IA allows filtering just like the 16700/702 environments. You may filter on any label, when using the filter tags label you can select symbols to make choosing transactions easier. To create a filter, choose Tools->New->Filter/Colorize. Then fill in the information on the window that opens up. You must create a new filter for each item you want filtered. To remove filters that you no longer want, go to Tools->Overview and then choose the filter you want removed and click Delete.

## PC Mapper

The PCI Analysis Probe PC Mapper software is an enhanced version of the PCI Analysis Probe inverse assembler and is for use only with PCI Analysis Probe from FuturePlus Systems Corporation. The enhancement includes PCI I/O and memory address decode to indicate common PC access.

### Setting up the Analyzer from the diskette

After the configuration file is loaded the PCI PC Mapper software can be loaded:

1. Install the PCI Analysis Probe software flexible diskette in the disk drive of the logic analyzer.
2. Configure the menu to "Load" the analyzer with the appropriate file (see table).

Logic Analyzer	File name
16500B mainframe with 16555, 16550, 167x, or 16540/541 logic analyzer	IAPCIMXE
16500B mainframe with 16510	IAPCIMX
16500A mainframe (all logic analyzer models)	IAPCIMX
166x series (with REV 2.2 system software)	IAPCIMXE
165x logic analyzers	IAPCIMX

3. Execute the load operation to load the file into the logic analyzer.

**IAPCIEXE is the inverse assembler for all logic analyzers installed into the 16700 and is auto loaded when the configuration file is loaded.**

### Setting up the 16700 for PC Mapper

To select PC Mapper function on the 16700, select INVASM from the state listing display then select PREFERENCES. When you select PREFERENCES it will come up with a box and there you can choose to turn on PC Mapper or suppress PC Mapper. The picture below displays PC Mapper function enabled on the 16700.

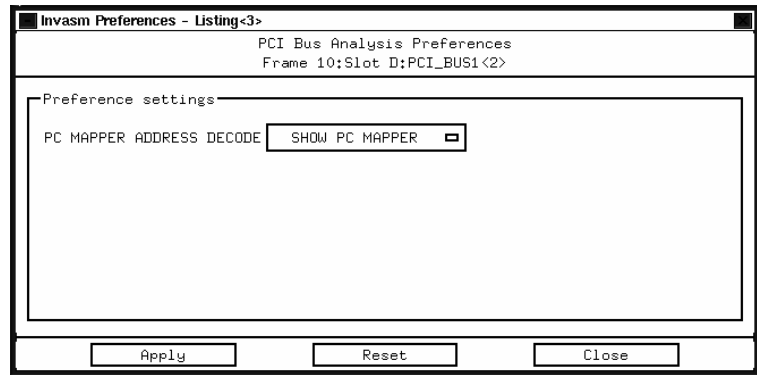

## Setting up the 1680/90/900 for PC Mapper

### Acquiring Data

PC Mapper is currently not available on the 1680/90.

Data can be acquired by touching the RUN button. As soon as there is activity on the bus, the logic analyzer will begin to acquire data. The analyzer will continue to acquire data and will display the data when the analyzer memory is full, the trigger specification is TRUE or when you touch STOP.

The logic analyzer will flash "Slow or Missing Clock" if the PCI Clock signal is not being detected by the logic analyzer. In this case, check the logic analyzer to PCI Analysis Probe connection (refer to your User's Manual).

## The State Display with the PCI PC Mapper

Captured data is as shown in the following figure. The first figure displays the state listing after disassembly. The PCI PC Mapper is constructed so the mnemonic output closely resembles the actual commands, status conditions, messages and phases specified in the PCI Local Bus specification. Symbols have also been defined to help aid in analysis. The non-disassembled state listing displays PCI bus mnemonics in addition to data. All data is displayed in hex. One exception is the decode of the address for a CONFIGURATION READ or a CONFIGURATION WRITE transaction. The Function (FUNC=) and Bus (BUS=) data is displayed in decimal.

100/500MHz LA E	Listing 1	Invasm Options	Print	Run
Markers Time	Trig to X 0 s	Trig to 0 0 s	X to 0 0 s	

Label>	PCI BUS TRANSACTIONS	Time	C/B3_0
Base>	PC MAPPER PRE-RELEASE VERSION	Relative	Hex
39	RTC/CMOS RAM DATA PORT I/O WRITE ADR=00000071 REQ64 D32=xxxx00xx	2.960 us	3
40		1.168 us	D
41	VIDEO MEMORY MEM WRITE ADR=000B81E0 REQ64 D32=xxxxxx30	41.55 us	7
42		72 ns	E
43	VGA CRT CNTRLR ADDR REG I/O WRITE ADR=000003D4 REQ64 D32=xxxx000E	4.832 us	3
44		264 ns	C
45	VGA CRT CNTRLR ADDR REG I/O WRITE ADR=000003D4 REQ64 D32=xxxxF10F	440 ns	3
46		264 ns	C

The above display data using the PCI Inverse Assembly software without the PCI PC Mapper functionality is shown as follows.

100/500MHz LA E    Listing 1    Invasm Options    Print    Run

Markers Time    Trig to X 0 s    Trig to 0 0 s    X to 0 0 s

Label>	PCI BUS TRANSACTIONS		Time	C/B3_0
Base>	REV 2.2		Relative	Hex
37	I/O WRITE ADR=00000070	REQ64#	1.200 us	3
38	D32=xxxxxx8F		1.072 us	E
39	I/O WRITE ADR=00000071	REQ64#	2.960 us	3
40	D32=xxxx00xx		1.168 us	D
41	MEM WRITE ADR=000B81E0	REQ64#	41.55 us	7
42	D32=xxxxxx30		72 ns	E
43	I/O WRITE ADR=000003D4	REQ64#	4.832 us	3
44	D32=xxxx000E		264 ns	C
45	I/O WRITE ADR=000003D4	REQ64#	440 ns	3
46	D32=xxxxF10F		264 ns	C
47	I/O WRITE ADR=00000070	REQ64#	4.064 us	3

### Display with PC Mapper enabled on the 16700

Listing<4>

File Window Edit Options Invasm Source Help

Goto Markers Search Comments Analysis Mixed Signal

Label ACK/RQ Hex X when Present Next Prev

Advanced searching Set G1 Set G2

State Number	FUTUREPLUS SYSTEMS c 2000	CYCLE	Time	USR7_1
Decimal	PCI BUS TRANSACTIONS REV 2.8	Symbols	Absolute	Hex
0	SYSTEM MEMORY	MEM_RD	0 s	00
1	MEM READ ADR=F3FC0000			
2	WAIT-NO DEVICE SELECT	WAIT_NODEVSE	16.000 ns	00
3	D32=12345678	DATA_FINALXF	88.000 ns	00
4	SYSTEM MEMORY	MEM_WR	111.687 ms	00
5	MEM WRITE ADR=F3FC0004			
6	WAIT-NO DEVICE SELECT	WAIT_NODEVSE	111.687 ms	00
7	D32=9ABCDEF0	DATA_FINALXF	111.687 ms	00
8	SYSTEM MEMORY	MEM_RD	223.194 ms	00
9	MEM READ ADR=F3FC0004			
10	WAIT-NO DEVICE SELECT	WAIT_NODEVSE	223.194 ms	00
11	D32=9ABCDEF0	DATA_FINALXF	223.195 ms	00

## Display with PC Mapper suppressed on the 16700

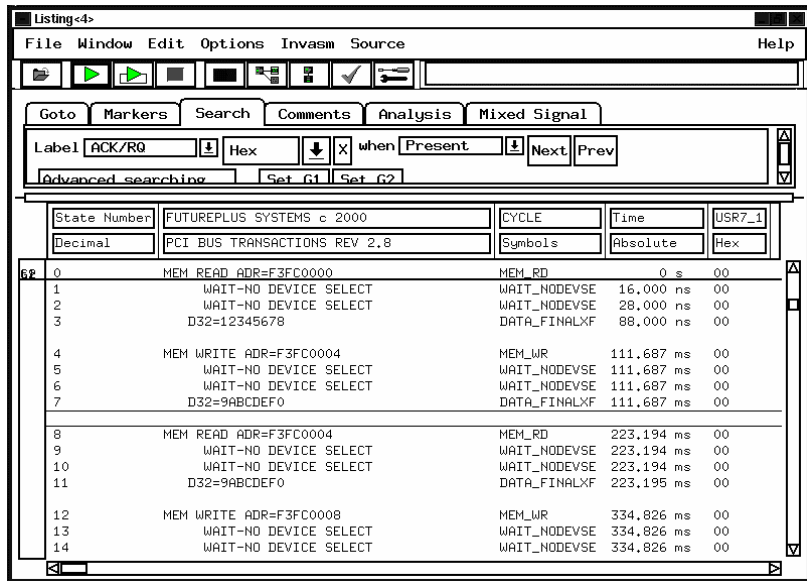

## Error Messages

The error messages reported by the PCI PC Mapper are the same as those reported with the standard non mapper version of the PCI Inverse Assembler.

## PCI PC Mapping for memory transactions

This section lists the addresses, the commands and the corresponding mapping done by the PCI PC Mapper software. For information on the standard PCI configuration register mapping please refer to the PCI Local Bus Specification Rev 2.0.

Address bits 23-0	PC Mapper output
greater than 0FFFFFFH	System Memory
0FFFFFF-0E0000H	System BIOS
0DFFFFFF-0C0000H	ROM Scan
0BFFFFFF-0A0000H	Video Memory
09FFFFFF-000400H	System Memory
0003FF-000000H	See Interrupt Vector Table

## Interrupt Vector Table

Address bits 23-0	PC Mapper output
0003C4H	INT #F1-FF USER PROGRAMS
000200H	INT #80-F0 BASIC
0001E0H	INT #78-7F USER PROGRAMS
0001DCH	INT #77 IRQ15
0001D8H	INT #76 IRQ14
0001D4H	INT #75 IRQ13
0001D0H	INT #74 IRQ12
0001CCH	INT #73 IRQ11
0001C8H	INT #72 IRQ10
0001C4H	INT #71 IRQ9
0001C0H	INT #70 IRQ8
0001A0H	INT #68-6F RESERVED
00019CH	INT #67 EXP MEM MANG
000180H	INT #60-66 USER PROGRAMS
00012CH	INT #4B-5F RESERVED
000128H	INT #4A USER RTC ALARM
00011CH	INT #47-49 RESERVED
000118H	INT #46 HD DISK #1 PARAM
000110H	INT #44-45 RESERVED
00010CH	INT #43 VIDEO CHAR TABLE
000108H	INT #42 EGA BIOS
000104H	INT #41 HD DISK #0 PARAM
000100H	INT #40 FLOPPY DISK ISR
000080H	INT #20-3F RESERVED DOS
00007CH	INT #1F VIDEO CHAR TABLE
000078H	INT #1E FLOPPY PARAMS
000074H	INT #1D AVAILABLE
000070H	INT #1C AVAILABLE
00006CH	INT #1B KEYBOARD BREAK
000068H	INT #1A RTC ISR
000064H	INT #19 BOOSTRAP LOADER
000060H	INT #18 ROM BASIC
00005CH	INT #17 LPT PRINTER BIOS
000058H	INT #16 KEYBOARD BIOS
000054H	INT #15 SYS SERVICE BIOS
000050H	INT #14 SERIAL PORT BIOS
00004CH	INT #13 FLOPPY DISK BIOS
000048H	INT #12 MEM SIZE INT
000044H	INT #11 EQUIP LIST
000040H	INT #10 VIDEO BIOS
00003CH	INT #0F IRQ7 LPT1
000038H	INT #0E IRQ6 FLOPPY DISK
000034H	INT #0D IRQ5 LPT2
000030H	INT #0C IRQ4 SERIAL #1
00002CH	INT #0B IRQ3 SERIAL #2
000028H	INT #0A IRQ2 SLAVE INT
000024H	INT #09 KEYBOARD
000020H	INT #08 IRQ0 SYS TIMER
00001CH	INT #07 NUM COPROCESSOR
000018H	INT #06 INVALID OPCODE
000014H	INT #05 PRINT SCREEN
000010H	INT #04 OVERFLOW DETECT

Address bits 23-0	PC Mapper output
00000CH	INT #03 BREAKPOINT TRACE
000008H	INT #02 NMI
000004H	INT #01 SINGLE STEP
000000H	INT #00 DIVIDE BY ZERO

## PCI PC Mapping - I/O Transactions

Address bits 23-0	PC Mapper output
0000H	MSTR DMA CH 0
0001H	MSTR DMA CH 0
0002H	MSTR DMA CH 1
0003H	MSTR DMA CH 1
0004H	MSTR DMA CH 2
0005H	MSTR DMA CH 2
0006H	MSTR DMA CH 3
0007H	MSTR DMA CH 3
0008H	MSTR DMA STAT REG
0009H	UNKNOWN IO DEVICE
000AH	MSTR DMA MASK REG
000BH	MSTR DMA MODE REG
000CH	MSTR DMA CLR BYTE PTR
000DH	MSTR DMA MSTR CLEAR
000EH	MSTR DMA CLEAR MASK
000FH	MSTR DMA WRT MASK
0018H	MSTR DMA CH EXT FUNCT REG
001AH	MSTR DMA EXT FUNCT
0020H	MSTR INT REQ REG
0021H	MSTR INT REQ REG2
0040H	INTERVAL TIMER TIMER 0
0042H	INTERVAL TIMER SPKR TIMER
0043H	INTRVAL TIMER #1 CNTRL
0044H	INTERVL TIMER #2 WATCHDOG
0047H	INTERVAL TIMER #2 CNTRL
0060H	KEYBOARD/MOUSE DATA PORT
0061H	SYSTEM CONTOL PORT B
0064H	KEYBOARD/MOUSE CMD PORT
0070H	RTC/CMOS RAM ADDR PORT
0071H	RTC/CMOS RAM DATA PORT
0074H	EXT CMOS RAM ADDR PORT
0075H	EXT CMOS RAM ADDR PORT
0076H	EXT CMOS RAM DATA PORT
0081H	CH 2 DMA PAGE REGISTER
0082H	CH 3 DMA PAGE REGISTER
0083H	CH 1 DMA PAGE REGISTER
0087H	CH 0 DMA PAGE REGISTER
0089H	CH 6 DMA PAGE REGISTER
008AH	CH 7 DMA PAGE REGISTER
008BH	CH 5 DMA PAGE REGISTER
008FH	CH 4 DMA PAGE REGISTER
0090H	ARB CNTRL POINT REG
0091H	FEEDBACK REG
0092H	SYSTEM CONTROL PORT A
0094H	SYS SETUP/CARD ENABLE REG
0096H	ADAPTOR SETUP/ENABLE REG
00A0H	SLAVE INTERRUPT CNTRLR
00A1H	SLAVE INTERRUPT CNTRLR
00C0H	SLAVE DMA CH4 MEM ADDR
00C2H	SLAVE DMA CH4 TRANS COUNT
00C4H	SLAVE DMA CH5 MEM ADDR
00C6H	SLAVE DMA CH5 TRANS COUNT

Address bits 23-0	PC Mapper output
00C8H	SLAVE DMA CH6 MEM ADDR
00CAH	SLV DMA CH6 TRANS COUNT
00CCH	SLAVE DMA CH7 MEM ADDR
00CEH	SLAVE DMA CH7 TRANS COUNT
00D0H	SLV DMA STATUS REG CH 4-7
00D4H	SLV DMA MASK REG CH 4-7
00D6H	SLAVE DMA MODE REG CH 4-7
00D8H	SLAVE DMA CLEAR BYTE PNTR
00DAH	SLAVE DMA MASTER CLEAR
00DCH	SLV DMA CLR MASK CH 4-7
00DEH	SLAVE DMA WRITE MASK REG
00E0H	IBM MODELS - ENCODE REG
00E1H	IBM MODELS - ENCODE REG
00F1H	NUMERIC COPROCESSOR RESET
00F8H	NUMERIC COPROCESSOR PORT
00F9H	NUMERIC COPROCESSOR PORT
00FAH	NUMERIC COPROCESSOR PORT
00FBH	NUMERIC COPROCESSOR PORT
00FCH	NUMERIC COPROCESSOR PORT
0100H	ADAPTER CARD POS REG 0
0101H	ADAPTER CARD POS REG 1
0102H	SYS BD/ADP CD POS REG 2
0103H	SYS BD/ADP CD POS REG 3
0104H	ADAPTER CARD POS REG 4
0105H	ADAPTER CARD POS REG 5
0106H	ADAPTER CARD POS REG 6
0107H	ADAPTER CARD POS REG 6
0278H	PARALLEL PORT 3 DATA PORT
0279H	PARALLEL PORT 3 STAT PORT
027AH	PARALLEL PORT 3 CMD PORT
02F8H	SERIAL PORT 2 XMIT/REC
02F9H	SER PORT 2 DIV LATCH/INT
02FAH	SERIAL PORT 2 INT ID REG
02FBH	SERIAL PORT 2 CNTRL REG
02FDH	SERIAL PORT 2 MODEM CNTRL
02FEH	SERIAL PORT 2 MODEM STAT
02FFH	SERIAL PORT 2 SCRTCH REG
0378H	PARALLEL PORT 2 DATA PORT
0379H	PARALLEL PORT 2 STAT PORT
037AH	PARALLEL PORT 2 CMD PORT
03B4H	VGA CRT CNTRLR ADDR REG
03B5H	VGA CRT CNTRLR DATA REG
03BAH	VGA STAT 1/FEATURE CNTRL
03BCH	PARALLEL PORT 1 DATA PORT
03BDH	PARALLEL PORT 1 STAT PORT
03BEH	PARALLEL PORT 1 CMD PORT
03C0H	VGA ATTRIBUTE CNTRLR ADDR
03C1H	VGA ATTRIBUTE CNTRLR DATA
03C2H	VGA OUTPUT/STAT REG
03C3H	VGA VIDEO SUBSYSTEM ENABLE
03C4H	VGA SEQUENCER ADDR REG
03C5H	VGA SEQUENCER DATA REG

Address bits 23-0	PC Mapper output
03C6H	VIDEO DAC PEL MASK
03C7H	VIDEO DAC PAL ADDR/STAT
03C8H	VIDEO DAC PAL ADDR/WRITE
03C9H	VIDEO DAC PALETTE DATA
03CAH	VGA FEATURE CONTROL REG
03CCH	VGA MISC OUTPUT REG
03CEH	VGA GRAPHICS CNTRLR ADDR
03CFH	VGA GRAPHICS CNTRLR ADDR
03D4H	VGA CRT CNTRLR ADDR REG
03D5H	VGA GRAPHICS CNTRLR DATA
03DAH	VGA COLOR STAT 1/FEATURE
03F0H	FLOPPY STATUS REG A
03F1H	FLOPPY STATUS REG B
03F2H	FLOPPY DIGITAL OUTPUT REG
03F4H	FLOPPY DISK CNTRLR STAT
03F5H	FLOPPY DISK CNTRLR DATA
03F7H	FLOPPY CONFIG CONTROL REG
03F8H	SERIAL PORT 1 XMIT/RCV BUF
03F9H	SER PORT 1 DIV LATCH/INT
03FAH	SERIAL PORT 1 INT ID/FIFO
03FBH	SERIAL PORT 1 LINE CNTRL
03FCH	SERIAL PORT 1 MODEM CNTRL
03FDH	SERIAL PORT 1 STAT REG
03FEH	SERIAL PORT 1 MODEM STAT
03FFH	SERIAL PORT 1 SCRATCH REG
0680H	MANUFACTURING CHECKPOINT PORT

# Timing Analysis

## Installation Quick Reference

Since the FS2000 interface contains only passive matching terminators it introduces negligible skew to the PCI Local Bus signals.

The following procedure describes the major steps required to perform timing analysis measurements with the FS2000 module.

1. Set the jumpers to the appropriate position on the FS2000 module. See page 9 of this manual for details.
2. After removing the probe tip assemblies, plug the logic analyzer cables into the Analysis Probe cable headers. See page 9 of this manual for details.
3. Install the FS2000 module into a slot in the target PCI Local bus.
4. Load the logic analyzer configuration file by loading the appropriate file. See page 11 of this manual for details.

## Acquiring Data

Touch RUN and, as soon as there is activity on the bus, the logic analyzer will begin to acquire data. The analyzer will continue to acquire data and will display the data when the analyzer memory is full, the trigger specification is TRUE or when you touch STOP.

The logic analyzer will flash "Waiting for Trigger" if the trigger specification has not been met.

# The Waveform Display

Captured data is displayed as shown in the following figure.

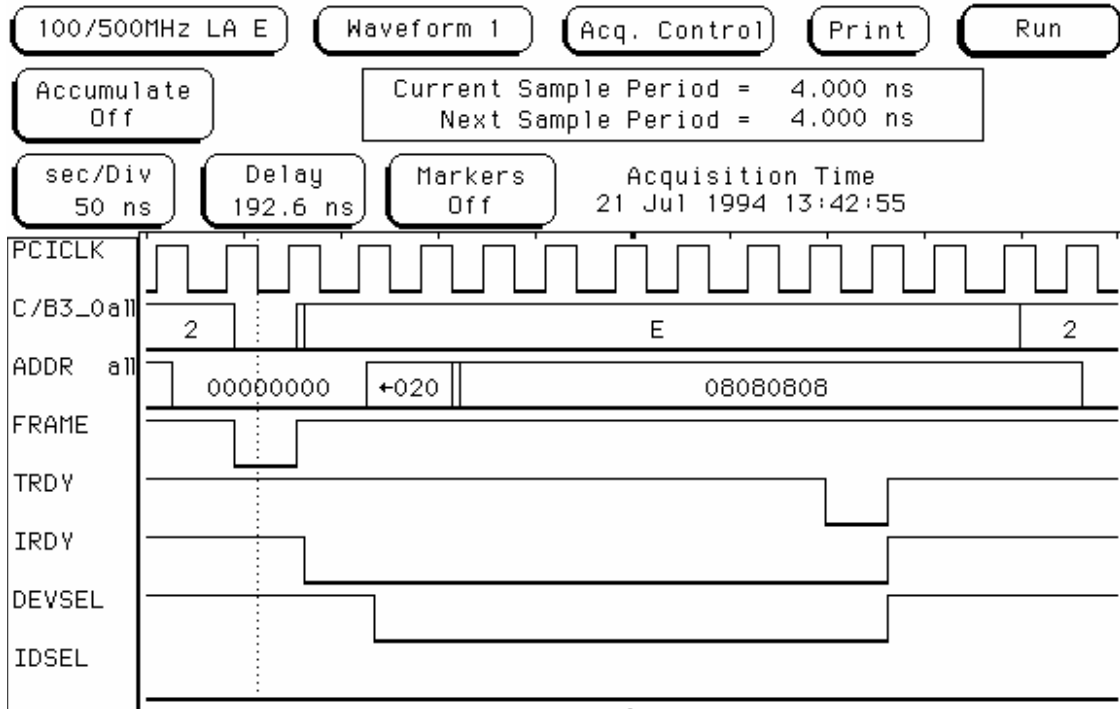

# General Information

This chapter provides additional reference information including the characteristics and signal connections for the FS2000 module.

## **Characteristics**

The following operating characteristics are not specifications, but are typical operating characteristics for the FS2000 module.

### ***Analysis Probe Interface Compatibility***

32 bit PCI Local bus accepting the short card length and universal connector pinout. All PCI local bus ground pins of the universal board pinout are connected to the ground plane of the FS2000 module.

### ***Card Edge Extender Connector***

This connector is a 5V, 32 bit connector that accepts either a long or short card form factor. All of the signals from the PCI bus are routed to the card edge extender connector.

### ***JTAG Boundary Scan***

The FS2000 does not implement JTAG Boundary SCAN. Pins TDI and TBO (pins 4a and 4b on the PCI local bus) are connected to JP2. If the jumper is across pins 2 and 3 then TDI and TDO are connected together so the scan chain is not broken. If the jumper is connected across pins 1 and 2 the PCI add-in card is in control of these signals.

### ***Standards Supported***

The PCI Local Bus Specification Revision 2.0

### ***Power Requirements***

The FS2000 Analysis Probe logic contains no active components and therefore requires no power. The PCI add-in card installed in the FS2000 can draw power from the +/-12V, 3.3V and the 5V pins as if it were installed without the FS2000.

### ***Logic Analyzer Required***

166x, 1661, 1662, 1655x, 167x, 16510, 1650, 16540/541, 1671x, 1674x, 1675x, 1695x, 1691x, 1680/90/900.

### ***Number of Probes Used***

The Analysis Probe interface uses 4 cable headers.

### ***Minimum Clock Period (State)***

Not limited by the Analysis Probe interface logic. Clocking is specified by the logic analyzer.

### ***Signal loading***

The FS2000 Analysis Probe logic presents one 10pf/90k ohm load on each PCI bus signal. The card edge extender connector adds an addition 2pf. If stake pins are installed as test points they add 1pf. If the test points are configured with an additional PCI connector this connector adds approximately 2pf. The etch and associated via's add approximately 1pf of additional capacitance.

***Etch length***

The etch length from the gold finger card edge to the pad of the extender card edge connector is approximately 4 inches on all signals. The signals are all daisy chained from the gold finger card etch to the test point to the Analysis Probe logic and then to the pads of the card edge extender connector.

***Operations***

All PCI Local Bus operations supported by the hardware and the inverse assembler.

***Environmental  
Temperature***

Operating: 0 to 55 degrees C (+32 to +131 degrees F)

Non operating: -40 to +75 degrees C (-40 to +167 degrees F)

***Altitude***

Operating: 4,600m (15,000 ft)

Non operating: 15,300m (50,000 ft)

***Humidity***

Up to 90% non condensing. Avoid sudden, extreme temperature changes which would cause condensation on the FS2000 module.

***Testing and  
Troubleshooting***

There are no automatic performance tests or adjustments for the FS2000 module. If a failure is suspected in the FS2000 module contact the factory or your FuturePlus Systems authorized distributor.

***Servicing***

The repair strategy for the FS2000 is module replacement. However, if parts of the FS2000 module are damaged or lost contact the factory for a list of replacement parts.

## Signal Connections

The FS2000 contains 4, forty pin headers for connection to Agilent logic analyzers and test points for scope or flying lead logic analyzer connection.

### Test Point pinout

The FS2000 test points can be configured as:

- Stake pins on side A
- Stake pins on side B
- Side A PCI connector
- Blank test points

If a PCI connector is installed the pinout is per the PCI specification for a 5V card.

The below figure gives the pinout of the test points as seen from side A.

5V ACK64 AD01 AD03 3.3V AD08 AD10 GND CBE1 SERR PERR GND 3.3V GND AD17 AD19 GND CBE3 AD25 GND AD81 REQ CLK RSV GND RSV INTD 5V TDO TCK  
 5V 5V GND AD05 AD07 GND AD12 AD14 3.3V 3.3V LOCK DESEL RDY CBE2 3.3V AD21 AD23 3.3V AD27 AD29 5V GND GND GND IRSN2 IRSN1 INIB 5V GND -12V  
 5V REQ64 AD00 GND AD06 CBE0 GND AD13 AD15 GND SDONE STOP TRDY HRAVE AD16 GND AD22 IDSEL GND AD28 AD80 GND 5V RSV GND 5V 5V INTA TDI 12V  
 5V 5V AD02 AD04 3.3V AD09 AD11 3.3V PAR SBO 3.3V GND GND 3.3V AD18 AD20 3.3V AD24 AD26 3.3V RSV GNT RST GND RSV RSV INTC 5V TMS TRST

The below figure gives the pinout of the test points as seen from side B.

TCK TDO 5V INTD RSV GND RSV CLK REQ AD31 GND AD25 CBE3 GND AD19 AD17 GND 3.3V GND PERR SERR CBE1 GND AD10 AD08 3.3V AD03 AD01 ACK64 5V  
 -12V GND 5V INTB IRSN1 IRSN2 GND GND GND 5V AD29 AD27 3.3V AD23 AD21 3.3V CBE2 RDY DESEL LOCK 3.3V 3.3V AD14 AD12 GND AD07 AD05 GND 5V 5V  
 12V TDI INTA 5V 5V GND RSV 5V GND AD30 AD28 GND IDSEL AD22 GND AD16 HRAVE TRDY STOP SDONE GND AD15 AD13 GND CBE0 AD06 GND AD00 REQ64 5V  
 TRST TMS 5V INTC RSV RSV GND RST GNT RSV 3.3V AD26 AD24 3.3V AD20 AD18 3.3V GND GND 3.3V SBO PAR 3.3V AD11 AD09 3.3V AD04 AD02 5V 5V

### The Analysis Probe interface pinout

The FS2000 module monitors signals for both state and timing analysis. The below figure displays how the cable headers are numbered.

39	37	35	33	31	29	27	25	23	21	19	17	15	13	11	9	7	5	3	1
40	38	36	34	32	30	28	26	24	22	20	18	16	14	12	10	8	6	4	2

The following tables list the FS2000 cable headers and the corresponding PCI Local Bus signals after these signals have been terminated by the 90K ohm/10pf terminators.

Analysis Probe Cable Header and Pin number	Logic Analyzer channel number	PCI Signal name
Header 1 pin 3	CLK/16	User pin 1
5	no connect	
7	15	AD15
9	14	AD14
11	13	AD13
13	12	AD12
15	11	AD11
17	10	AD10
19	9	AD09
21	8	AD08
23	7	AD07
25	6	AD06
27	5	AD05
29	4	AD04
31	3	AD03
33	2	AD02
35	1	AD01
37	0	AD00

Analysis Probe Cable Header and Pin number	Logic Analyzer channel number	PCI Signal name
Header 2 pin 3	CLK/16	User pin 2
5	no connect	
7	15	AD31
9	14	AD30
11	13	AD29
13	12	AD28
15	11	AD27
17	10	AD26
19	9	AD25
21	8	AD24
23	7	AD23
25	6	AD22
27	5	AD21
29	4	AD20
31	3	AD19
33	2	AD18
35	1	AD17
37	0	AD16

Analysis Probe Cable Header and Pin number	Logic Analyzer channel number	PCI Signal name
Header 3 pin 3	CLK/16	PCI Clock here for 166x/550 and 16510 State analysis. Controlled by JP1
5	no connect	
7	15	PCI Clock 16510 Timing analysis only. Controlled by JP1
9	14	INTD#
11	13	INTC#
13	12	INTB#
15	11	INTA#
17	10	RST#
19	9	C/BE3#
21	8	C/BE2#
23	7	C/BE1#
25	6	C/BE0#
27	5	DEVSEL#
29	4	STOP#
31	3	LOCK#
33	2	PERR#
35	1	SERR#
37	0	PAR

Analysis Probe Cable Header and Pin number	Logic Analyzer channel number	PCI Signal name
Header 4 pin 3	CLK/16	
5	no connect	
7	15	Reserved pin A09
9	14	Reserved pin B10
11	13	Reserved pin A11
13	12	Reserved pin B14
15	11	Reserved pin A14
17	10	Reserved pin A19
19	9	TRDY#
21	8	FRAME#
23	7	IRDY#
25	6	SDONE
27	5	SBO#
29	4	REQ#
31	3	GNT#
33	2	IDSEL
35	1	ACK64#
37	0	REQ64#

# Mechanical Drawing FS2000

